

## HRO 3.5 Series Reverse Osmosis Systems

HRO 3.5-Series Reverse Osmosis Systems are manufactured for light commercial applications and feature a compact wall mount space-saving design. The HRO 3.5-Series come pre-assembled and ready for immediate on-line service with minimal set up and simple utility connections.

HRO 3.5-Series Reverse Osmosis Systems have been engineered for capacities of 200 and 300 gallons per day and feature a single pump design for enhanced performance.

### Features

- 5 Micron Sediment Pre-Filter
- 10 Micron Carbon Block Pre-Filter and Post-Filter
- Pentek® 10" Filter Housings
- HF4 Extra Low Energy Membrane
- Fiberglass Membrane Housing
- 0 – 300 psi Glycerin-Filled Pump Pressure Gauge
- 0 – 100 psi Glycerin-Filled Pre-Filter Pressure Gauge
- 0 – 100 psi Glycerin-Filled Permeate Pressure Gauge
- John Guest® Push/Pull Fittings with Locking Safety Clips
- Aquatec® High Flow Booster Pump
- Aquatec® Tank Pressure Switch
- Aquatec® Feed Solenoid Valve
- Aquatec® Auto Flush Timer Valve

### Options and Upgrades

- 10" and 20" Floor Stands
- Product Water Storage Tanks
- HF5 Ultra Low Energy Membrane (For Cold Water Applications)
- Stainless Steel Membrane Housing
- HM Digital® DM-2 TDS Meter
- Pentek® 20" Filter Housings



HRO 3.5-300  
Wall Mount  
Reverse Osmosis System

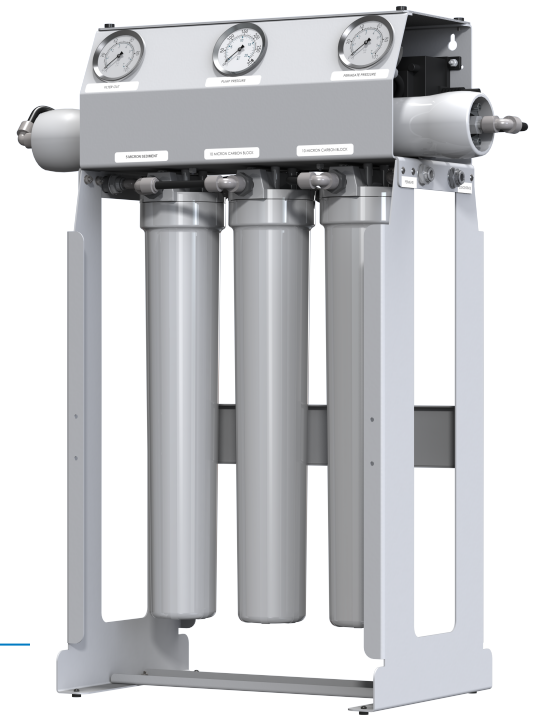

HRO 3.5-300  
Reverse Osmosis System  
with Optional 20" Stand  
and 20" Filter Housings

Engineered Water Treatment Solutions

# HRO 3.5 Series Reverse Osmosis Systems

PRODUCT SPECIFICATIONS		
		HRO 3.5-300
<b>Design</b>		
Configuration		Single Pass
Feed Water Source (ppm)		TDS <1000
Standard Recovery*		50%
<b>Rejection and Flow Rates</b>		
Nominal Salt Rejection		98.5%
Permeate Flow* (gpm / lpm)		0.21 / 0.79
Concentrate Flow (gpm / lpm)		0.21 / 0.79
<b>Connections</b>		
Feed (in)		3/8 Tube
Permeate (in)		3/8 Tube
Concentrate (in)		3/8 Tube
<b>Membranes</b>		
Membrane Per Vessel		1
Membrane Quantity		1
Membrane Size		2521
<b>Vessels</b>		
Vessel Array		1
Vessel Quantity		1
<b>Pumps</b>		
Pump Type		Aquatec 5800
<b>Electrical</b>		
Standard Voltage		110V, 60Hz, 1Ph 1.0A
Voltage Options		220V, 50Hz, 1Ph, 0.5A
<b>System Dimensions</b>		
L x W x H (in / cm)		9 x 27 x 19 / 22.9 x 68.6 x 48.3
Weight (lb / kg)		50 / 22.7

\* Product flow and recovery rates are based on feedwater conditions of 550 TDS at 77°F at 100 psi. Treatment ability of the RO system is dependent on feedwater quality. Higher TDS and/or lower temperatures will reduce product flow. Performance projections should be run for each installation.

## Operating Limits

Design Temperature	77°F	Max. Turbidity NTU ^	1
Max. Feed Temperature	85°F	Max. Free Chlorine ppm	0
Min. Feed Temperature	40°F	Max. TDS ppm	1,000
Max. Ambient Temperature	120°F	Max. Hardness GPG ^^	1
Min. Ambient Temperature	40°F	Max. pH (Continuous)	11
Max. Feed Pressure psi	85	Min. pH (Continuous)	3
Min. Feed Pressure psi	45	Max. pH (Cleaning 30 Min.)	12
Max. Operating Pressure psi	120	Min. pH (Cleaning 30 Min.)	2
Max. SDI Rating	<3		

**Test Parameters:** Static pressure tested.

^ Appropriate filtration must be installed in order to prevent premature membrane fouling.

^^ Scale prevention measures must be taken to prolong membrane life.



404 Moravian Valley Road  
 Waunakee, WI 53597  
 www.hellenbrand.com

