



ProMate Series Twin Alt Manual



Consumer's Manual

800671 Rev C.
3/12/19
©2015-2019

Manufactured by:
HELLENBRAND

404 Moravian Valley Road • Waunakee, Wisconsin 53597
hellenbrand.com • info@hellenbrand.com

This owner's manual is designed to assist owners and installers with the operation, maintenance and installation of your new water softener. It is our sincere hope that this manual is clear, concise and helpful to both owner and installer. We have included detailed instructions on general operating conditions, pre-installation and installation instructions, start-up, and timer and meter programming. We have included a troubleshooting guide, service instructions and parts diagrams to assist you.

Owners will appreciate the simplified, illustrated format for operation, programming and troubleshooting. **In the event that you need professional assistance for servicing your water softener, please contact the dealer who installed this system.**

TABLE OF CONTENTS

Job Specification Sheet.....	3
Soft Water Basics.....	4
Operating Conditions.....	4
Pre-Installation Check List.....	5
Water Softener Disinfection.....	5
Bypass Valve Operation.....	5
Installation Instructions.....	6
Programming.....	7
Installer Programming.....	8
Water Softener Draining Procedure.....	9
Troubleshooting.....	10-12
Parts Diagrams.....	13-20
Installation Fittings.....	21-22
Specifications.....	23
Warranty.....	24

Dealer Name _____ Phone _____

Address _____ Email _____

JOB SPECIFICATION SHEET

MODEL NO. _____

*WATER TEST AT TIME OF INSTALLATION

_____ Hardness CaCO₃ (gpg) _____ Other _____
_____ Iron (ppm) _____ Other _____
_____ pH _____ Other _____

OPTIONAL RELAY SETTINGS

_____ Off

AUX MAV

_____ Brine Reclaim Enabled
_____ Separate Source Enabled

Relay 1 Trigger

_____ **On Time**
_____ Start Time, Minutes into Regeneration
_____ Run Time

_____ **On Gallons**
Pulse per _____ Gallons
_____ Time Relay Closed

_____ **On Regen Gallons**
(Relay activated by flow through meter during service & regeneration)
Pulse per _____ Gallons
_____ Time Relay Closed

_____ **On Service Alarm**
_____ Years
_____ Gallons

Relay 2 Trigger

_____ **On Time**
_____ Start Time, Minutes into Regeneration
_____ Run Time

_____ **On Gallons**
Pulse per _____ Gallons
_____ Time Relay Closed

_____ **On Regen Gallons**
(Relay activated by flow through meter during service & regeneration)
Pulse per _____ Gallons
_____ Time Relay Closed

_____ **On Service Alarm**
_____ Years
_____ Gallons

_____ **Error**

*SIZING INFORMATION

All Water is Softened Except:

_____ Rear Hose Bib _____ Front Hose Bib _____ Kitchen Cold _____ Toilets _____ All Cold
_____ Other _____

The average family uses 50 gallons per person daily for all water uses in the home, about 40 gallons per person daily if soft water is not supplied to the toilets, and about 30 gallons per person daily if only hot water is softened.

_____ Daily Water Usage (Gallons/Person)
x _____ Family Size (Number of people in family)
= _____ Total Gallons Per Day
x _____ Grains Per Gallon of Hardness
(Note: Add 3 grains per gallon of hardness for each ppm iron for total compensated hardness)
= _____ Total Grains Per Day

*INSTALLATION DATE _____

*SERIAL NUMBER _____

NOTES _____

SOFT WATER BASICS

Hardness

Excess amounts of calcium and magnesium in water produce hardness. A water softener removes the majority of calcium and magnesium to produce softened water.

Hardness is measured in terms of grains. (This grain weight is derived from the average weight of a dry grain of wheat.) When your water is tested the grain hardness is calculated and expressed as grains per gallon (gpg). This calculation, as well as the number of people in your household will help determine what type and size of water softener will most efficiently soften your water.

Your water softener contains an ion exchange media (often called resin) which removes the hardness from water as it flows through each softener tank. Eventually so much hardness collects on the exchange media that the softener can no longer soften the water in that tank. At this point it is considered "exhausted". The twin alternating function automatically switches to the standby tank and regeneration occurs immediately on the exhausted tank.

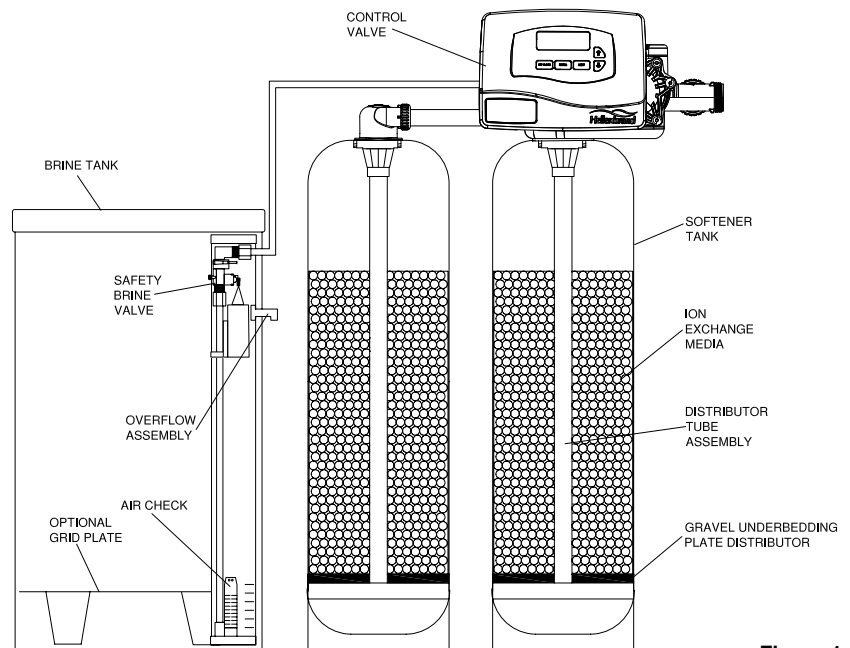

Figure 1

Regeneration

To regenerate the exchange media, it must be rinsed with a brine (salt) solution. This removes the hardness from the exchange media and replaces it with sodium. The exchange media is then ready to remove hardness from water. The hardness minerals and excess brine solution are rinsed down the drain.

During the regeneration cycle the softening media is also backwashed. This reversing of the normal flow of water serves to remove sediment which may have accumulated during the softening process due to the filtering action of the exchange media. Backwashing also loosens and fluffs up the bed of exchange media to insure that during regeneration the brine solution will come into contact with all the media.

Maintenance of Your Softener

Salt: Salt to a softener is what gasoline is to a car. Not only must a softener have salt, but it should be the proper type to insure efficient recharging of the unit. Ask your dealer what type of salt may best suit your needs. Always have an adequate supply of salt on hand. Check the salt level of your brine tank every couple of weeks initially to determine how much salt you use - this will depend on how much water you use. As a rule of thumb, with 20 gpg hard water, about a 1/2 lb. of salt per person per day is used. In other words, a family of four uses 60 lbs. of salt a month. Fill the tank approximately three-fourths full, with a minimum of 12" of salt. If your household does not use much water, do not fill your salt keeper over 1/2 full, salt bridging may occur in the brine tank. This may result in hard water due to ineffective regeneration. **DO NOT USE Block Salt** when the ProMate-TA control is programmed with a brine tank prefill. Block salt does not dissolve quickly enough to provide a good regeneration.

Cleaning Salt Tank: The salt tank may require periodic cleaning. Inspect the salt tank at least once a year for buildup of insoluble materials. It is recommended to periodically clean the salt tank no matter what kind of salt you are using. See page 9, Miscellaneous #2 for details on cleaning.

REMEMBER: Salt is the fuel to run your water softener. Buy the **best clean salt available.**

OPERATING CONDITIONS

Your water conditioner has been designed to adequately handle up to 100 grains per gallon of hardness as well as up to 2 ppm of ferrous bicarbonate iron. This is iron that is dissolved in water and not visible to the eye in a freshly drawn sample. After standing in contact with air, the ferrous iron will become oxidized to the ferric state and start to precipitate as a reddish brown floc. It can be seen and may cause discolored water. In order for your softener to remove the iron, air (oxygen) must be kept from coming in contact with water until after it has been

passed through the water conditioner. In some cases, additional equipment may be required to treat water supplies having special characteristics, such as: ferric hydroxide iron, iron bacteria, low pH, taste and odors, etc. If any question should exist, contact your dealer.

This water softener is not intended to be used for treating water that is microbiologically unsafe or of unknown quality without adequate disinfection before or after treatment.

PRE-INSTALLATION CHECK LIST

(All electrical & plumbing should be done in accordance to all local codes)

Water Pressure: A minimum of 25 pounds of water pressure (psi) is required for regeneration. Maximum 125 psi.

Water Quality: On rural water supplies there is often a problem with sand or sediment in the water. (This problem occasionally occurs in public water supplies.) If the water is not filtered before being softened, the sand and sediment may plug up the water softener restricting the flow through the resin bed. This problem often requires rebedding of the mineral tank. **Note:** Well and/or pump problems affecting the operation of the softener are repairs that are not covered under warranty. To prevent these unnecessary, and expensive repairs that are not covered under warranty, we recommend the installation of an in-line filter system ahead of a water softener.

Electrical: A continuous 110 volt 60 cycle current supply is required. Make certain the current supply is uninterrupted and cannot be turned off with another switch. All electrical connections must be connected per local codes. **Surge protection is recommended with all electric controls.**

Existing Plumbing: Existing plumbing must be free from lime and iron build-up. Piping that is built-up heavily with lime and/or

iron must be replaced. If piping is blocked with iron, additional equipment must be installed ahead of the water conditioner to correct the problem.

Drain Line: The softener should be located close to a drain. Avoid overhead drain lines if possible to prevent back pressure on the brine injector. Overhead drains are not to exceed 8 feet above the floor and no more than 20 feet in length. The pipe size for the drain line should be a minimum of 3/4". Backwash flow rates in excess of 7 gpm or length in excess of 20' require 1" drain line.

Bypass Valves: Always provide for the installation of a bypass valve.

Softening: It is recommended that the conditioner be installed to soften both the hot and cold water supply. A separate hard water faucet may be plumbed for drinking purposes if desired. Outside faucets should be left on hard water.

Caution: Water temperature is not to exceed 110°F; the conditioner cannot be subject to freezing conditions, or to a vacuum due to loss of pressure (such as a water main break).

WATER SOFTENER DISINFECTION

The construction materials of your water softener will not support bacterial growth nor will these materials contaminate a water supply. However, the normal conditions existing during shipping, storage, and installation indicate the advisability of disinfecting a softener after installation, before the softener is used to treat potable water. In addition, during normal use a softener may become fouled with organic matter or in some cases, with bacteria from the water supply.

Therefore, every water softener should be disinfected after installation, some will require periodic disinfection during their normal life. You have two choices for disinfection as follows:

- A. SODIUM HYPOCHLORITE (household bleach)
5.25% SODIUM HYPOCHLORITE solutions are available under such trade names such as Clorox, Lincio, Bo Peep,

White Sail and Eagle Brand Bleach. If stronger solutions are used, such as those sold for commercial laundries, adjust the dosage accordingly.

- 1. Dosage:
 - a. Softening resin; 1.2 fluid ounce per cubic foot of resin.
 - 2. Add the required amount of hypochlorite solution to the brine well of the brine tank.
 - a. Proceed with the normal regeneration. Press REGEN and allow the water softener to go through a normal regeneration.
- B. EPA and NSF approved Sani-System by Pro Products. This can be purchased from your water treatment provider or at: <http://proproducts.com/products/sani-system>.

BYPASS VALVE OPERATION

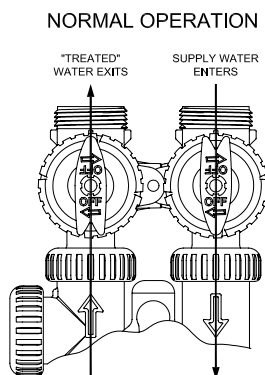

Figure 3

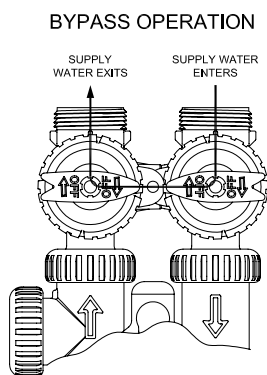

Figure 4

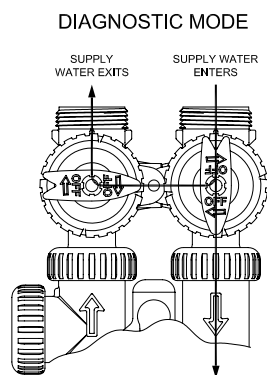

Figure 5

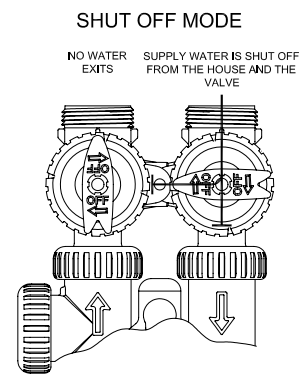

Figure 6

INSTALLATION INSTRUCTIONS

(All electrical & plumbing should be done in accordance to all local codes)

CAUTION:

- Do not use vaseline, oils or other hydrocarbon lubricants or spray silicone anywhere. A silicon lubricant may be used on black o-rings but is not necessary. **Avoid any type of lubricants, including silicone, on red or clear lip seals.**
 - Do not use paste or other sealants on threads. Only teflon tape may be used on threads. Teflon tape is not necessary on the nut connection or caps because of o-ring seals.
 - The pipe size for the drain line should be a minimum of 3/4". Backwash flow rates in excess of 7 gpm or length in excess of 20' require 1" drain line.
1. Place the conditioner where it is to be installed, making sure each tank is on a clean, level and firm base.
 2. Do all necessary plumbing (inlet to inlet, outlet to outlet and drain line to drain). The control valve, fittings and/or bypass are designed to accommodate minor plumbing misalignments but are not designed to support the weight of a system or the plumbing.
 3. When assembling the installation fitting package (inlet and outlet), connect the fitting to the plumbing system first and then attach the nut, split ring and o-ring. Heat from soldering or solvent cements may damage the nut, split ring or o-ring. Solder joints should be cool and solvent cements should be set before installing the nut, split ring and o-ring. Avoid getting primer and solvent cement on any part of the o-rings, split rings, bypass valve or control valve.
 4. **A jumper ground wire should be installed between the inlet and outlet pipe whenever the metallic continuity of a water distribution piping system is interrupted. Install grounding strap on metal pipes.**

5. Some contractors make drain line connection using 5/8" polytube (See figure 6a) or a 3/4" female adapter. If soldering, joints near the drain must be done prior to connecting the drain line flow control fitting. Leave at least 6" between the drain line control fitting and solder joints when soldering pipes that are connected on the drain line control fitting. Failure to do this could cause interior damage to the drain line flow control fitting.
6. The brine refill flow control assembly is installed in an easy to access refill elbow located on top of the control valve. The refill flow control assembly is attached to the control valve with a locking clip. The locking clip allows the elbow to rotate 270 degrees so the outlet can be orientated towards the salt tank.
7. Connect the brine line found in the brine tank to the brine connection on the control valve. The control valve has a standard refill elbow to which a 3/8" flexible tube can be connected, see figure 6a. (An optional elbow can be ordered which accommodates a 1/2" flexible tube for a high regenerant draw rate situation). Both elbows use the same refill flow control and retainer. Make sure the floor is clean beneath the salt tank and that it is level and smooth.
8. A 1/2" (inside diameter) gravity drain line may be connected to the overflow fitting on the side of the brine tank. This overflow is in case of a malfunction in the brine shut off. If the unit is installed where water may flow in the event of an overflow and cause water damage, connect a length of flexible tubing and run to a drain below the level of the overflow. (**Do not connect the tubing to the drain line on the control valve. Do not run tubing above overflow height at any point.**)

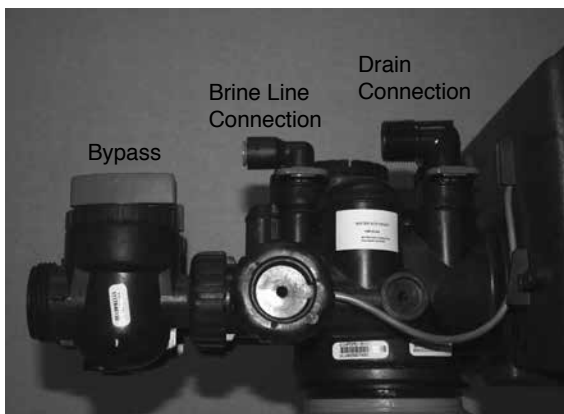

Figure 6a

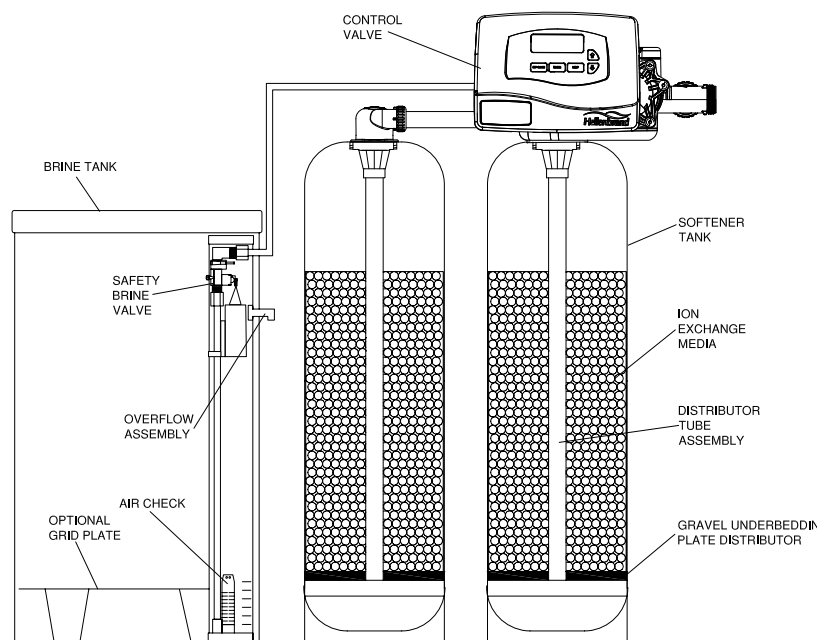

Figure 6b

PROGRAMMING

General Information

The ProMate TA control valve is the “brain” of your twin alternating water softener. It consists of the valve body and powerhead with solid state microprocessor.

The display panel (see Figure 7) consists of the LCD display and five push buttons which are used in displaying and programming the water softener settings.

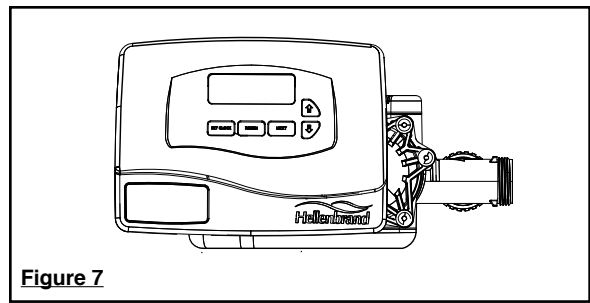

Figure 7

Initial Start Up

The initial start up will probably be done by the technician installing the softener system. If not, the following instructions will step through the process.

1. Complete all plumbing connections: inlet, outlet, drain line and brine line. Do not add salt at this time.
2. Place the bypass valve in the bypass position. (See figure 3 page 5) Turn on the main water supply. Open a cold soft water faucet to flush the piping of any air and/or foreign material. Run until the water is clear.
3. Manually add 6 inches of water to the brine tank.
4. Now plug the transformer into a 110-volt receptacle. (Be certain the outlet is uninterrupted.) Within 5 seconds the control will automatically align itself into the softening mode and display will automatically alternate between time of day, gal/min and gallons remaining. (Figure 8).
5. Set the time of day by pushing clock button (figure 9, page 8) and using ▲ and ▼ buttons.
6. Push REGEN button and hold it down for 3 seconds. The system will advance to the “First” position. (Note: Depending on how the system is programmed it could read backwash, rinse, brine or fill). Pushing REGEN button until “Rinse” shows in the left upper hand corner of display. Slowly place the bypass into the “diagnostic mode” (see fig 4, page 5). Run water to the drain until it runs clear. Return the bypass valve to the by-pass position (fig 3, page 5). Push REGEN button until unit is back to softening mode. **Repeat with second tank.**
7. Once again, push REGEN button and hold down for 3 seconds. Keep pressing REGEN button until “Backwash” appears. Slowly place the bypass valve into the

“Diagnostic Mode” 1/2 way. Allow water to slowly fill the mineral tank. When a solid stream of water starts coming out of the drain line, open the bypass inlet valve all the way and allow to run until the drain until water clears. Then slowly place the by-pass into the “normal operation” mode by opening the outlet side of bypass valve, figure 2, page 5.

8. Press the REGEN button until LED display says “REGENERANT DRAW DN”. Loosen the brine line from the elbow on control valve in the brine tank. Place finger over the end of the elbow to check for suction. If no suction, see trouble-shooting guide. (See #10, Page 11) If proper suction, reattach brine tube and allow it to draw water down to the bottom of the air check, (figure 6b, page 6).
9. Press REGEN button again until LED once again displays “BACKWASH”. Keep in backwash until water once again runs clear at the drain. **Backwash both tanks.**
10. Press REGEN button again until “RINSE” is displayed. Allow rinse cycle to run its full course. While the rinse cycle is finishing, load brine tank with salt. If utilizing brine reclaim, manually add full volume of water to brine tank for first regeneration.
11. Once the rinse cycle has finished the softener control will return to the softening cycle. The LED screen will scroll between “TIME/GPM/GALLONS REMAINING”.
12. Next set your softeners water hardness and regeneration time settings (see figure 10a, page 8).

Your programming is now complete.

General Operation

When the system is operating, one of several displays may be shown. Pressing NEXT will alternate between the displays. The tank in service is displayed on the left. One of the displays is the current time of day. The second display is the following: days to a regen/gallons remaining. Capacity remaining is the number of gallons that will be treated before that tank goes through a regeneration cycle. The third display is current flow in gal/min. The user can scroll between the displays as desired by pushing NEXT or display will scroll automatically.

When water is being treated (i.e. water is flowing through the system) the word “GPM” flashes on left side of display when other than flow rate is displayed.

Unit A is the tank the control valve is on and Unit B is the tank with in/out head.

USER DISPLAYS/SETTINGS

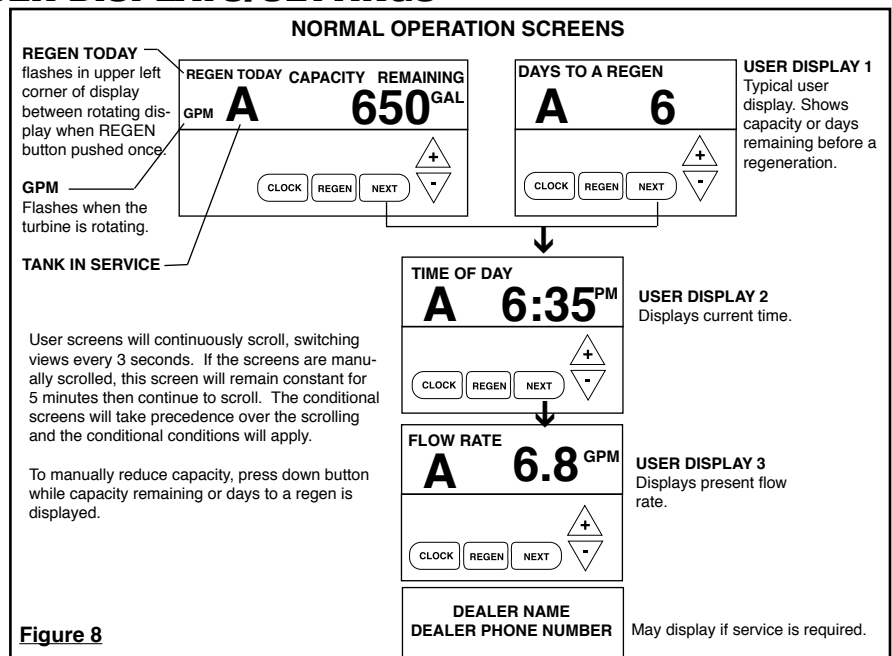
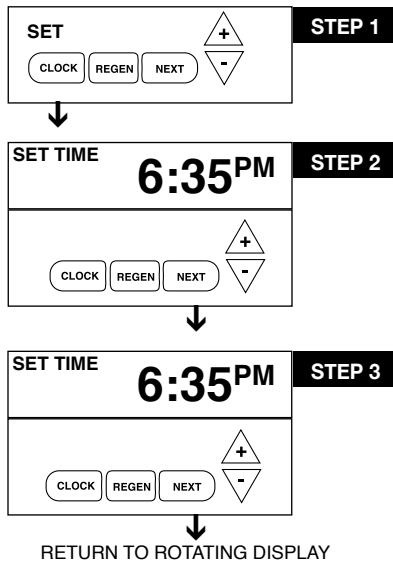

Figure 8

SET TIME OF DAY



▲ = ▲ Up Arrow ▼ = ▼ Down Arrow

Step 1 - Press SET CLOCK.

Step 2 - Current Time (**hour**): Set the hour of the day using ▲ or ▼ buttons. AM/PM toggles after 12. Press NEXT to go to step 3.

Step 3 - Current Time (**minutes**): Set the minutes of day using ▲ or ▼ buttons. Press NEXT to exit Set Clock. Press REGEN to return to previous step.

Power Loss - Lithium battery on circuit board provides up to 2 years of time clock backup during power outages. If the power is out when battery is depleted, only time of day needs to be reset, all other values are stored in non-volatile memory. When time of day is flashing, replace lithium coin type 2032 battery.

Battery back-up feature will be activated after 24 hours of power.

Do not forget to reset for daylight savings time.

Figure 9

INSTALLER DISPLAYS/SETTINGS

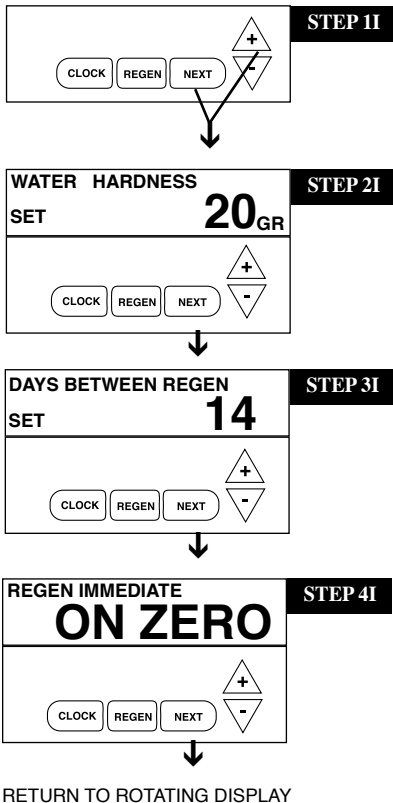

▲ = ▲ Up Arrow ▼ = ▼ Down Arrow

Step 1I - Press NEXT and ▲ simultaneously for 3 seconds.

Step 2I - Hardness: Set the amount of total compensated hardness in grains (hardness as calcium carbonate) per gallon using ▲ or ▼ buttons. **The factory setting is 20** with value ranges from 1 to 150 in 1 grain increments. Note: The grains per gallon should be increased if soluble iron needs to be reduced. Add 3 grains of hardness for each ppm of iron present. If this display shows nA -, then system is set-up in "filter" mode or "AUTO" is not selected in softener system setup. (See page 23). Press NEXT to go to Step 3. Press REGEN to exit Installer Displays/Settings.

Step 3I - Day Override: This sets the number of days between regenerations. If value set to "oFF" regeneration initiation is based solely on gallons used. If value is set as a number (allowable range from 1 to 28) a regeneration initiation will be called for on that day even if sufficient number of gallons were not used to call for a regeneration. Set Day Override using ▲ or ▼ buttons. As twin alternating configuration is soft applied for salt and water efficiency: **Factory setting is Off.**

- number of days between regeneration (1 to 28); or
- "oFF"

Press NEXT to go to step 4. Press REGEN to return to previous step.

Step 4I - Regeneration: This display will show REGEN IMMEDIATE, ON ZERO GAL-LONS, when set for twin alternating.

Figure 10a

Manual Regeneration

To initiate a manual transfer of tank, press and hold REGEN button. This will initiate a regeneration on the tank previously in service and put standby tank into service.

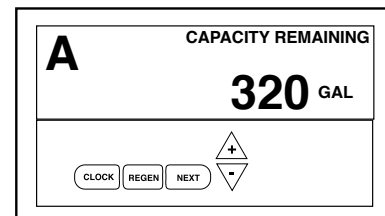

WATER SOFTENER DRAINING PROCEDURE

In cold weather climates it is common for plumbing systems that are not in use to be "winterized" or drained of all water to prevent any damage that may be caused by the excessive expansion of water when it freezes. To prevent damage to a water softener it must be **properly** drained also. A simple way to properly drain or winterize a water softener is to use compressed air to force all of the water out of the softener mineral tank. The following procedure will explain the process:

- 1) Initiate the softener into a manual regeneration cycle. After the refill cycle, advance control to backwash and allow it to complete the backwash cycle (this will clean the media) and start into the brine-draw cycle. Allow the regeneration to continue in the brine draw cycle until the brine is drawn out of the salt tank and the air check at the bottom of the brine pick-up tube shuts off. This should be done with each tank. **NOTE: Be sure you have salt in the brine tank and allow 1 hour minimum to make a saturated brine. It is important that any liquid left in the softener tank when you finished blowing out system be saturated brine solution to prevent any damage to the softener.** At this time no more brine is introduced into the softener and the slow rinse process begins.
- 2) Turn the water supply inlet and outlet valves off to the water softener as soon as the air check shuts off and no more brine is being drawn into the softener (at the beginning of the slow rinse process).
- 3) Unplug the electric power leaving the softener control valve in the brine draw cycle.
- 4) Remove the brine refill elbow assembly from the control valve. Remove the refill flow control retainer assembly from the elbow. Reinstall the elbow assembly and secure with the locking clip. Disconnect the brine tube at the top of the salt keeper and force air into the brine tube toward the softener mineral tank and control valve. The air will force the brine/water solution that was drawn into the mineral tank out to drain through the control valve drain line. (An air compressor blow gun attachment with a portable air compressor works well.) Reinstall the brine line flow control retainer in side of the refill elbow assembly. Reinstall the brine refill elbow assembly and secure with locking clip.

CAUTION: You do not want to apply any more pressure than necessary to force the brine/water out of the mineral tank.

The small amount of brine/water that may be left in the mineral tank will not expand enough to cause any damage to the softener when it freezes.

If your softener is equipped with an optional bottom drain on the mineral tank, you will have to follow all of the same procedures with the exception of the need for compressed air. With the brine tube disconnected from the salt keeper, raise it to a level above the softener control valve and temporarily secure it in this position. Now open the drain valve at the bottom of the mineral tank and allow all brine/water to drain from the mineral tank.

CAUTION: If a hose is connected to the drain valve to direct the brine/water to a floor drain be sure it runs downward and is unobstructed. When brine/water quits running at the drain, be sure to leave the drain valve open until you start the system up again.

- 5) At this time the salt keeper has very little water left in it. What liquid is left in the salt keeper is saturated brine, provided that there is still salt left in the tank. Saturated brine will not freeze solid and cause any damage and does not have to be drained any further from the brine tank.

If there is no salt left in the salt keeper when the system is drained we recommend dumping all of the water out of the brine tank at this time. See brine tank cleaning instructions. (#2 in Miscellaneous section, below)

- 6) **CAUTION:** It is important at this time to be assured that the inlet/outlet water supply piping is properly drained. Depending on how the water supply piping was routed to the water softener control valve, a water loop or trap may have been created. Sometimes drain valve(s) are installed at the bottom of the loop to assure all water can be drained out. If not it may be necessary to disconnect the control valve from the piping system and open the inlet/outlet valve(s) to allow all the water to drain from the piping. This should be done after the rest of the plumbing system is drained.
- 7) Draining or winterizing of your softener is complete. Refer to the start-up procedures on page 7 when you are ready to start your softener.

MISCELLANEOUS

1. Salt Usage: See your water conditioning professional for a recommendation on the best type of salt for your application.
2. Brine Tank Cleaning:
 - a. Remove brine tank cover.
 - b. Scoop out as much old salt as possible.
 - c. Disconnect brine tubing from safety brine valve at brine well.
 - d. Remove safety brine valve from brine well.
 - e. Place one hand in brine well to hold overflow nut and remove 2-piece overflow.
 - f. Remove brine well and optional grid plate, if used, from brine tank.
 - g. Remove any remaining salt and/or impurities from brine tank.
 - h. Using clean water and a brush or rag, wipe and rinse inside of brine tank. Wipe and rinse the grid plate and brine well.
 - i. Reassemble brine tank reversing steps c - f. Note: If grid plate is used and it is damaged or cracked, replace with new one.
 - j. Put brine tank in place making sure there is no debris or foreign material beneath it.
 - k. Reconnect brine tubing to safety brine valve.
 - l. Manually add 6 inches of water to the brine tank (or to approximately 1" above the grid plate, if used).
 - m. Add new salt. Important: Do not add the old salt which was removed earlier unless it is clean and not mushy. We recommend using new salt.
 - n. Follow the disinfection instructions found on page 9.
 - o. Put on brine tank cover.

TROUBLE SHOOTING

PROBLEM

CAUSE

CORRECTION

After resolving the cause of any error code or any service work on valve, press NEXT & REGEN simultaneously for 5 seconds or disconnect power supply for 5 seconds at PC board and reconnect to resynchronize software with piston position.

VALVE ERROR CODES

Error Code 101 - Unable to recognize start of regeneration

A1. Control not reading piston position

- A1. Resynchronize software with piston position by pressing start of regeneration NEXT and REGEN buttons simultaneously for 5 seconds, until screen changes. Initiate regeneration to verify function by pressing and holding REGEN button until regeneration initiates, step through regeneration modes by pushing REGEN button each time motor stops.
- A2. Verify motor connection to PC board; motor wires intact and motor fully inserted to engage pinion.
- A3. Verify correct assembly; PC board snapped onto drive bracket and wires are in backplate guides and drive bracket snapped onto backplate. Verify three drive gears are in place on drive bracket.

Error Code 102 - Unexpected stall

B1. Mechanical Binding

- B1a. Check for any foreign material in stack assembly impeding piston movement and remove; verify seals intact and in place in stack assembly, if not replace stack assembly.
- B1b. Check for incorrect assembly, drive bracket not snapped into place, motor pushed inside of barrel of drive bracket (black gear on motor end should be flush with end of shaft).
- B1c. Drive gears unable to rotate freely - replace gear(s) if not rotating freely.

B2. Improper voltage being delivered to board

- B2. Motor unable to move piston, check voltage is present on 12V DC motor at start of regeneration modes. Transformer should provide at least 12 volts when plugged into outlet and not attached to board - if not replace transformer

Error Code 103 - Motor ran too long, timed out trying to reach next position

C1. High drive forces on piston

- C1. Loosen drive cap gear 1/4 turn
- C2. Address high drive forces

Error Code 104 - Motor ran too long, timed out trying to reach home position

D1. Piston unable to reach home position

- C3. Motor failure during regeneration-replace motor
- D1. Incorrect assembly; check drive bracket is correctly seated and snapped into place on backplate, wires outside of guides on backplate can impede drive bracket from correct position.
- D2. Check PC board is seated on posts and snapped into place on drive bracket
- D3. Drive gear labels dirty or missing, missing or broken gear, replace as needed

MAV ERROR CODES

After resolving any MAV error or servicing MAV, resynchronize software with piston positioning by pressing NEXT and REGEN buttons simultaneously for 5 seconds or disconnecting power from PC board for 5 seconds and reconnecting.

ALTERNATING MAV DRIVE - ERROR CODES 106 & 107

Error Code 106 - Alternating MAV ran too long

- A1. Control valve is programmed for alternating without having MAV wire connected to MAV drive on board. Reprogram valve to proper setting or connect MAV wire to MAV drive on PC board

Error Code 107 - Alternating MAV stalled

Mechanical Binding

- A2. MAV motor not fully engaged with gears
- B1. Open MAV drive and check for foreign material on stack assembly, remove if present, verify seals intact and in place. If not, replace stack assembly
- B2. Drive gear should spin freely-replace if necessary

AUXILIARY MAV DRIVE - ERROR CODES 116 & 117

Error Code 116 - Auxiliary MAV ran too long

- A1. Control valve is programmed for auxiliary MAV without having MAV connected to board. Reprogram valve to proper setting or connect MAV to two-pin connection labeled auxiliary drive on PC board

Error Code 117 - Auxiliary MAV stalled

Mechanical Binding

- A2. MAV motor not fully engaged with gears
- B1. Open MAV and check for foreign material on stack assembly, remove if present, verify seals intact and in place. If not, replace stack assembly
- B2. Drive gear and reducing gears should spin freely, replace if necessary

1. Control valve stalled in regeneration

- A. Motor not operating
- B. No electric power at outlet
- C. Defective transformer
- D. Defective PC board
- E. Broken drive gear or drive cap assembly
- F. Broken piston retainer
- G. Broken main or regenerant piston

- A. Replace Motor
- B. Repair outlet or use working outlet
- C. Replace transformer
- D. Replace PC board
- E. Replace drive gear or drive cap assembly
- F. Replace drive cap assembly
- G. Replace main or regenerant piston

TROUBLE SHOOTING

PROBLEM	CAUSE	CORRECTION
2. Control valve does not regenerate automatically when REGEN button is depressed and held	<ul style="list-style-type: none"> A. Transformer unplugged B. No electric power at outlet C. Broken drive gear or drive cap assembly D. Defective PC board 	<ul style="list-style-type: none"> A. Connect transformer B. Repair outlet or use working outlet C. Replace drive gear or drive cap assembly D. Replace PC board
3. Control valve does not regenerate automatically but does when REGEN button is depressed	<ul style="list-style-type: none"> A. Bypass valve in bypass position B. Meter connection disconnected C. Restricted/stalled meter turbine D. Programming error E. Defective meter F. Defective PC board 	<ul style="list-style-type: none"> A. Put control valve in service position B. Connect meter to PC board C. Remove meter and check for free rotation or foreign matter D. Check control valve set-up procedure E. Replace meter F. Replace PC board
4. Time of day flashes on and off	<ul style="list-style-type: none"> A. Battery back-up maintains time-of-day up to 2 years in event of power outage and battery is not depleted. Time of day flashes when battery is depleted. B. Prior to 2/2007, PC board did not have battery back-up - capacitor held time of day up to 2 hours. Power outage > 2 hours. 	<ul style="list-style-type: none"> A. Reset time of day and replace battery on PC Board (Lithium coin type battery 2032) B. Reset time of day.
5. Softener delivers hard water.	<ul style="list-style-type: none"> A. Bypass valve is open or faulty. B. No salt or low salt level in brine tank. C. Softener fails to draw brine. D. Excessive water usage. E. Insufficient brine level in brine tank. F. Resin level inadequate. G. Meter faulty. H. Raw water hardness fluctuation. 	<ul style="list-style-type: none"> A. Close bypass valve or replace. B. Add salt to brine tank and maintain salt level above water level. C. See problem #10. D. Check gallon capacity settings. E. Check brine refill setting and refill flow restrictor for blockage. F. See problem #7. G. Test meter and clean or replace meter. H. Test raw water hardness and adjust settings to highest known hardness.
6. Unit uses too much salt.	<ul style="list-style-type: none"> A. Improper brine refill setting. B. Improper settings. C. Excessive water in brine tank. D. Leaking faucets, toilets, etc... E. Brine line flow control out of place 	<ul style="list-style-type: none"> A. Check brine refill setting for proper salt dosage B. Check water hardness and reevaluate capacity setting specification C. See problem #9. D. Repair or replace those items. E. Replace Brine line flow control.
7. Loss of resin.	<ul style="list-style-type: none"> A. Backwash controller missing. B. Faulty distributor tube assembly. C. Air being drawn in through brine system. D. Air in water supply system 	<ul style="list-style-type: none"> A. Install backwash controller. B. Check distributor tube assembly for cracks or holes. C. Check for leaks in brine lines, fittings, or air check. Repair or replace. D. <ul style="list-style-type: none"> 1. Install upper distributor if missing. 2. Ensure that water supply system has an air eliminator.
8. Softener delivers salty water.	<ul style="list-style-type: none"> A. Low water pressure. B. Excessive water in brine tank. C. Wrong size injector. 	<ul style="list-style-type: none"> A. Check incoming water pressure - Must remain at minimum of 25 psi. B. See problem #9. C. Install correct injector.
9. Excessive water in brine tank.	<ul style="list-style-type: none"> A. Plugged injector. B. Faulty piston/seal assembly. C. Plugged or kinked drain line. D. Backwash flow controller closed off. E. Defective brine line flow control. 	<ul style="list-style-type: none"> A. Remove injector and clean ports. B. Replace piston/seal assembly. C. Correct any kinking or plugging of drain line. D. Check backwash flow controller. E. Replace brine refill flow control.
10. Softener fails to draw brine.	<ul style="list-style-type: none"> A. Injector is plugged, absent/missing oring(s) B. Faulty piston assembly. C. Brine line connection leak. D. Drain line plugged creating excess back pressure. E. Drain line too long or too high. F. Low inlet pressure. 	<ul style="list-style-type: none"> A. Remove injector and clean ports/replace if necessary B. Check piston assembly. C. Inspect brine line during refill cycle for leaks. D. Inspect drain line for blockage. E. Refer to drain line specifications. F. Increase inlet pressure to a minimum of 25 psi.
11. Continuous flow to drain.	<ul style="list-style-type: none"> A. Piston assembly failure. B. Motor failure. C. Circuit board failure. 	<ul style="list-style-type: none"> A. Replace piston assembly. B. Replace motor. C. Replace circuit board.
12. Loss of water pressure.	<ul style="list-style-type: none"> A. Iron build-up in resin. B. Resin bed fouled with sand or sediment. C. Resin bed mushing due to high amount of oxidizers in water supply (chlorine). 	<ul style="list-style-type: none"> A. See problem #13. B. Rebed softener and install sediment filter ahead of softener. C. Rebed softener. Install dechlorination system ahead of softener

TROUBLE SHOOTING

PROBLEM	CAUSE	CORRECTION
13. Iron in softened water.	A. Iron has fouled resin bed. B. Iron is not in a soluble state. C. Prefilter failure. D. Iron level excessive. E. Control fails to regenerate.	A. Use iron reducing resin cleaner to clean resin bed, and increase salt dosage or regenerate more frequently or rebed softener. Install an Iron Curtain System ahead of the softener. B. Test water to determine type of iron, install iron reduction system. C. Check prefilter. D. Install iron reduction system. E. See problem #3.
14. Absent or incomplete LED display	A. Transformer unplugged B. No electric power at outlet C. Defective transformer D. Battery < 3 volts E. Defective PC board	A. Plug transformer into uninterrupted outlet B. Repair outlet or use working outlet C. Replace transformer D. Replace 2032 battery E. Replace PC board
15. Control does not display correct time of day	A. Power outage > 2 years B. Power outage < 2 years, time of day flashing, battery depleted	A. Reset time of day B. Replace lithium coin type battery on circuit board Model 2032 battery
16. No "softening" or "filtering" display when water is flowing	A. Bypass valve in bypass position B. Meter connection disconnected C. Restricted/stalled meter turbine D. Defective meter E. Defective PC board	A. Put bypass valve in service position B. Connect meter to PC board C. Remove meter and check for free rotation, clean foreign material D. Replace meter E. Replace PC board
17. Control valve regenerates at wrong time of day	A. Twin Alternating softener can regenerate at any time	

PROMATE TWIN ALT CONDITIONER & BRINE TANK ASSEMBLIES

Item	Description	Qty	Part #
1	Downflow Metered Control Valve	1	110230
	Upflow Metered Control Valve	1	110142
2	Top Diffuser	2	101539
3&4	Mineral Tank Assembly		Item 3 & 4
	PM TA-024 8 x 44	2	110560
	PM TA-032 9 x 48	2	110561
	PM TA-032-10 10 x 44	2	110562
	PM TA-048 10 x 54	2	110563
	PM TA-064 13 x 54	2	110565
	PM TA-096 14 x 65	2	110566
	PM TA-128 16 x 65	2	110567
	PM TA-160 18 x 65	2	110568
	PM TA-192 21 x 62	2	110569
5	Ion Exchange Resin	x2"	110102
6	Underbedding		No underbedding required for Vortech Tank
7-15a	Brine Tank Assy (18x40)-Granite	1	104449
b	Brine Tank Assy (24x41)		104424
c	Brine Tank Assy (24x50)	1	104497
9a	Brine Tank Cover 18x40	1	101448
b	Brine Tank Cover 24x41		Included with 8b
c	Brine Tank Cover 24x50		Included with 8c
10-14 a	Safety Brine Valve Assy 41"		104172
b	Safety Brine Valve Assy 50"		104173
10	Cap, Brine Well	2	101365
11*	Safety Brine Valve	1	101274
12	Float Assembly	1	101660
13	Air Check	1	101181
14 a	Brine Well 40"-41"	1	102877
b	Brine Well 50"		102878
15	2-Piece Overflow	1	102217
16 a	Grid Plate 18" (optional)	1	101758
b	Grid Plate 24" (optional)	1	101754
17	Interconnect Fitting	1	
	8-10" Tanks - No Jackets		110194
	8-10" Tanks with Jackets		110185
	made for specific tank sizes on larger units		
18	In/Out Head	1	101777
-	Owners Manual (Not Shown)	1	800671

Item	Description	Qty	Part #
	Mineral Tank & Distributor Assy		
	Granite Tank Jacket		
			103626
			103630
			103633
			103638

*See Specifications for amount
No underbedding required for Vortech Tank

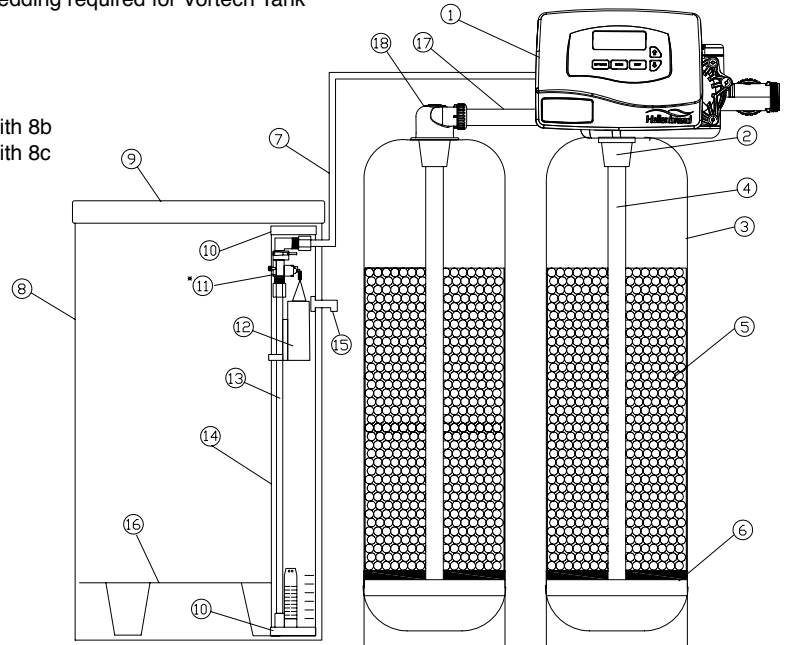

Stock code: 103841 - 36" Well - 40" Brine Tank
103845 - 46" Well - 50" Brine Tank

Brine Recovery Option

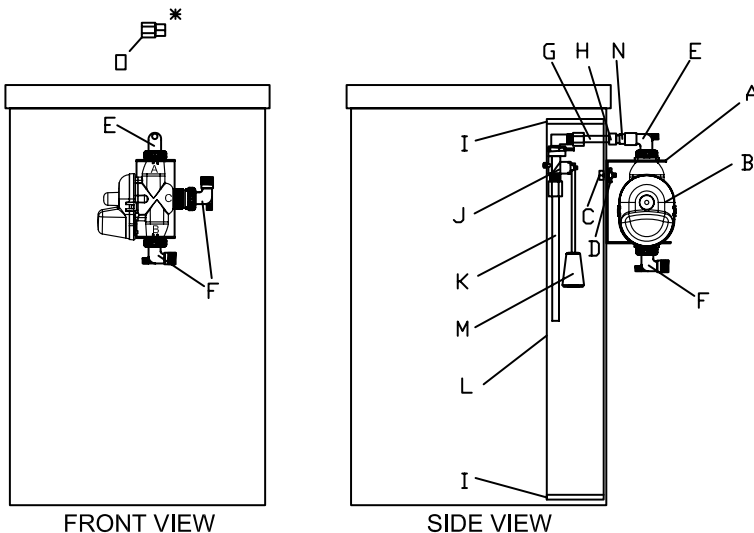

	Qty	P/N	Description
A	1	108015	1.25" Stainless Steel Bracket
B	1	102032	1.25" MAV FxFxF
C	1	108013	1/2"-13 1" Nylon Bolt
D	1	108012	1/2"-13 Nylon Wing Nut
E	0.5	101640	1" Solvent Elbow
F	1	101639	1" MNPT Plastic Elbow
G	0.25	102664	1/2"x12-1/2" PVC80 Tube
H	1	100415	Adapter 1/2" TxMNPT
I	2	101365	4" Well Cap
J	1	101275	474 Brine Valve
K	1	102664	1/2" x 12-1/2" Tube
L	1	102877	4"x36" Brine Well
	1	102878	4"x46" Brine Well
M	1	101660	Float
N	1	100342	Bushing 3/4"x1/2" SxF PV80
O	1	108565	Bushing 1"x3/4" TxT PV80

Note: MAV bracket can be removed and valve mounted if desired. Kit # 108469 required.

NOTE: Do not use 3/4" drain nut & insert (102131 & 101871) when installing connection between softener drain & MAV

FRONT COVER AND DRIVE ASSEMBLY

ITEM NO.	ORDER NO.	DESCRIPTION	QTY.
1	111569	Cover Assy	1
2	102096	Motor	1
3	101262	Drive Bracket & Spring Clip	1
4	109807	PC Board	1
5	101746	Drive Gear 12x36	3
6	101459	Drive Gear Cover	1
7	Relay Kit Options:		1
	103724	PCM Relay Installed	
	103723	PCM Relay Kit	
	103730	Pigtail Relay Installed	
	103729	Pigtail Relay Kit	
8	102385	Relay Only	1
Not Shown	111723	Transformer 110V-15V DC	1
9	110038	Battery	1

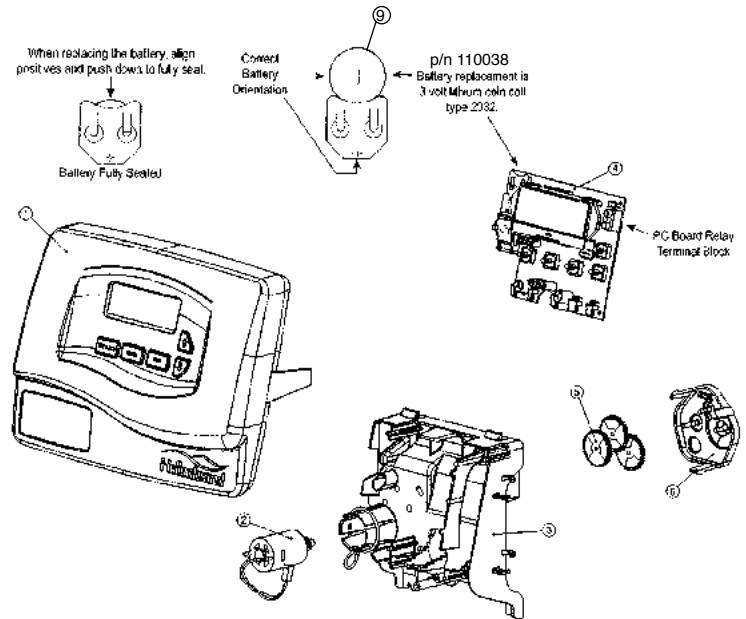

Figure 11

After completing any valve maintenance involving the drive assembly or the drive cap assembly and pistons, press and hold NEXT and REGEN buttons for 3 seconds or unplug power source jack from the printed circuit board (black wire) and plug back in. This resets the electronics and establishes the service piston position. The display should flash all wording, then flash the software version (ex: 214) and then reset the valve to the service position.

DRIVE CAP ASSEMBLY, DOWNFLOW PISTON, REGENERANT PISTON AND SPACER STACK ASSEMBLY

ITEM NO.	ORDER NO.	DESCRIPTION	QTY.
1	102548	Spacer Stack Assy	1
2	101613	Drive Cap Assy.	1
3	102167	O-Ring 228 - Drive Cap Assy.	1
4a	102292	Piston Downflow Assy.	1**
4b	102297	Piston Upflow Assy.	1
5	102296	Regenerant Piston	1
6	102192	O-ring 337-tank	1
7	102165	O-ring - Distributor Tube	1
8	101189	Back Plate	1
9	102892	Service Wrench - Not Shown	1

*102292 is labeled with DN and 102297 is labeled with UP.
 Note: The regenerant piston is not used in backwash only applications.
 **Standard Option.

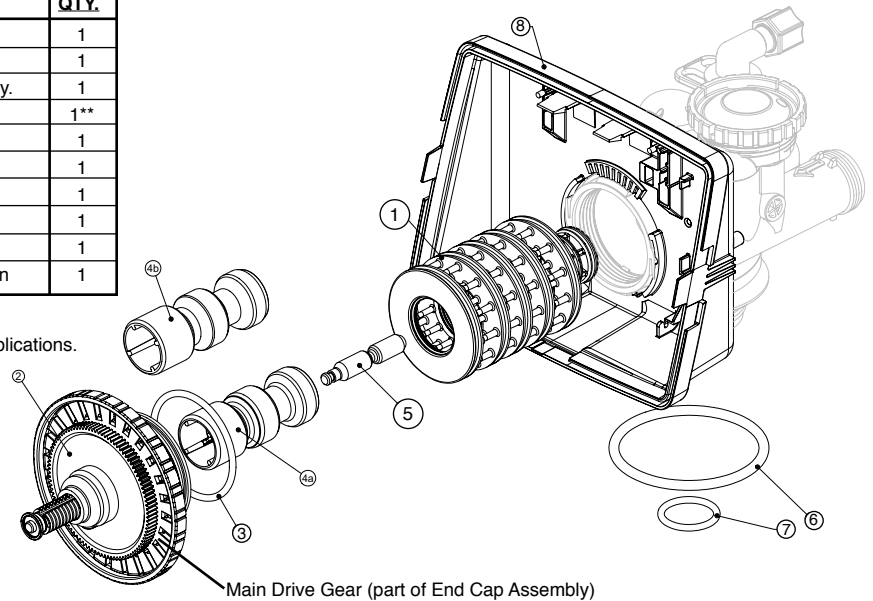

Figure 12

Do not use vaseline, oils, other hydrocarbon lubricants or spray silicone anywhere. A silicone lubricant may be used on black o-rings but is not necessary. **Avoid any type of lubricants, including silicone, on red or clear lip seals.**

After completing any valve maintenance involving the drive assembly or the drive cap assembly and pistons, press and hold NEXT and REGEN buttons for 3 seconds or unplug power source jack from the printed circuit board (black wire) and plug back in. This resets the electronics and establishes the service piston position. The display should flash all wording, then flash the software version (ex: 101.3) and then reset the valve to the service position.

INJECTOR CAP, INJECTOR SCREEN, INJECTOR, PLUG AND O-RING

ITEM NO.	ORDER NO.	DESCRIPTION	QTY.
1	101375	Injector Cap	1
2	102159	O-ring 135	1
3	102457	Injector Screen	1
4	102319	Injector Assy. Z Plug-Filter	1
5	101825	Injector Assy. A Black	1
	101826	Injector Assy. B Brown	
	101827	Injector Assy. C Violet	
	101828	Injector Assy. D Red	
	101829	Injector Assy. E White	
	101830	Injector Assy. F Blue	
	101831	Injector Assy. G Yellow	
	101832	Injector Assy. H Green	
	101833	Injector Assy. I Orange	
	101834	Injector Assy. J Light Blue	
	101835	Injector Assy. K Light Green	
Not Shown	106767	O-ring 011	*
Not Shown	106768	O-ring 013	*

* The injector plug and the injector each contain one 011 (lower) and 013 (upper) o-ring.

Note: For upflow position, injector is located in the up hole and injector plug in the down hole. For a filter that only backwashes injector plugs are located in both holes.

The nuts and caps are designed to be unscrewed or tightened by hand or with the special plastic wrench. If necessary a pliers can be used to unscrew the nut or cap. Do not use a pipe wrench to tighten or loosen nuts or caps. Do not place screwdriver in slots on caps and/or tap with a hammer.

Do not use pipe dope or other sealants on threads. Teflon tape must be used on threads of the 1" NPT connection and on the threads for the drain line connection. Teflon tape is not necessary on the nut connection nor caps because of o-rings seals.

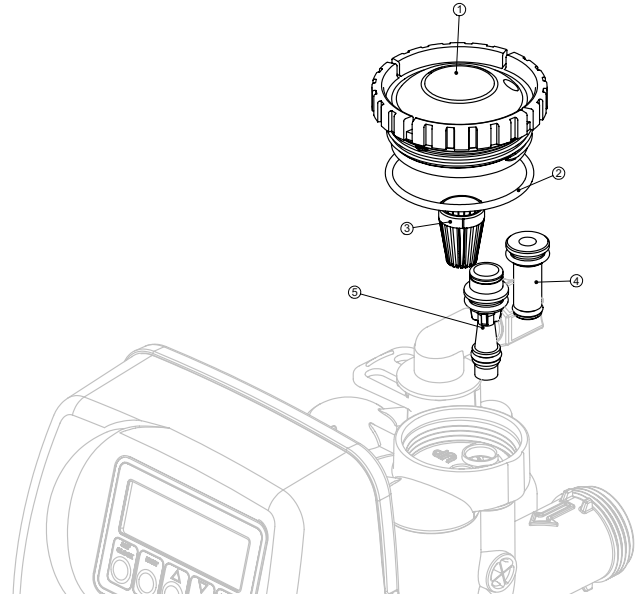
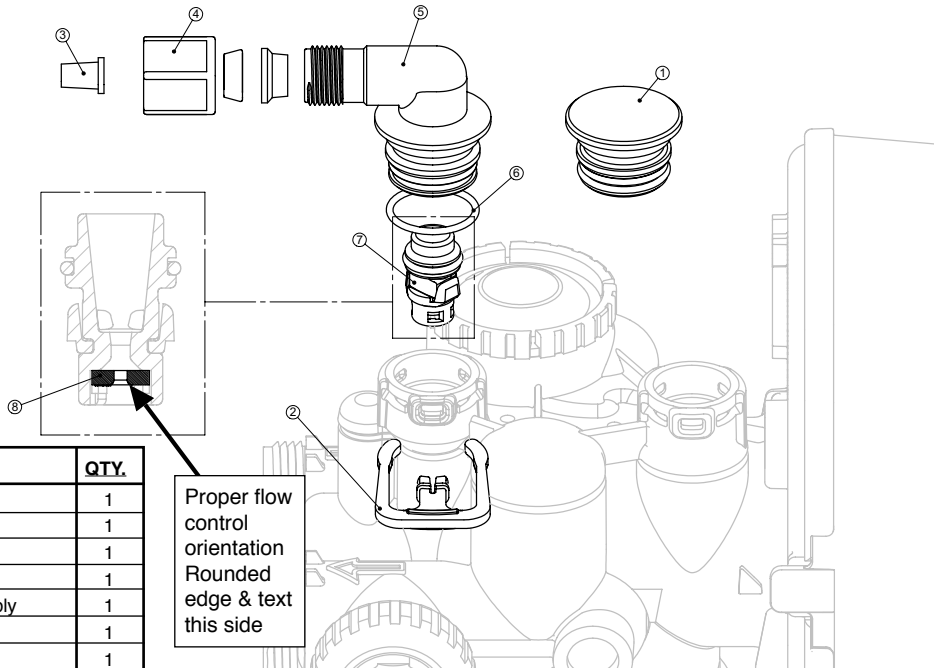

Figure 13

REFILL AND REFILL PORT PLUG



ITEM NO.	ORDER NO.	DESCRIPTION	QTY.
1	102322	Refill Port Plug Assy.**	1
2	101414	Elbow Locking Clip	1
3	101868	Polytube Insert 3/8	1
4	102130	Nut 3/8	1
5-8	103589	3/8" Refill Elbow Assembly	1
5	101620	Elbow Cap 3/8	1
6	102153	O-ring 019	1
7	102418	Refill Flow Cntrl Retainer Assy.	1
8	102421	Refill Flow Control Button	1
Not Shown	101617	1/2" Elbow w/Nut & Insert	1

*Assembly includes item #8.

**This part is required for backwash only systems.

Figure 14

DRAIN LINE - 3/4"

ITEM NO.	ORDER NO.	DESCRIPTION	QTY.
1	101414	Elbow Locking Clip	1
2	101871	Polytube Insert, 5/8"	Optional
3	102131	Nut 3/4" Drain Elbow	Optional
4-5	101618	Drain Elb 3/4" Male Assy-Vent	Optional
4-5	101619	Drain Elb 3/4" Male Assy-No Vent	1
5	102153	O-ring 019	1
6	102406	DLFC Retainer Assy.	1
7	101551	DLFC 0.7 gpm for 3/4"	One DLFC must be used if 3/4 fitting is used
	101552	DLFC 1.0 gpm for 3/4"	
	101556	DLFC 1.3 gpm for 3/4"	
	101559	DLFC 1.7 gpm for 3/4"	
	101574	DLFC 2.2 gpm for 3/4"	
	101577	DLFC 2.7 gpm for 3/4"	
	101583	DLFC 3.2 gpm for 3/4"	
	101588	DLFC 4.2 gpm for 3/4"	
	101591	DLFC 5.3 gpm for 3/4"	
	101593	DLFC 6.5 gpm for 3/4"	
	101594	DLFC 7.5 gpm for 3/4"	

Systems are shipped without 3/4" nut for drain elbow (polytube installation only) and 5/8" polytube insert (polytube installation only).

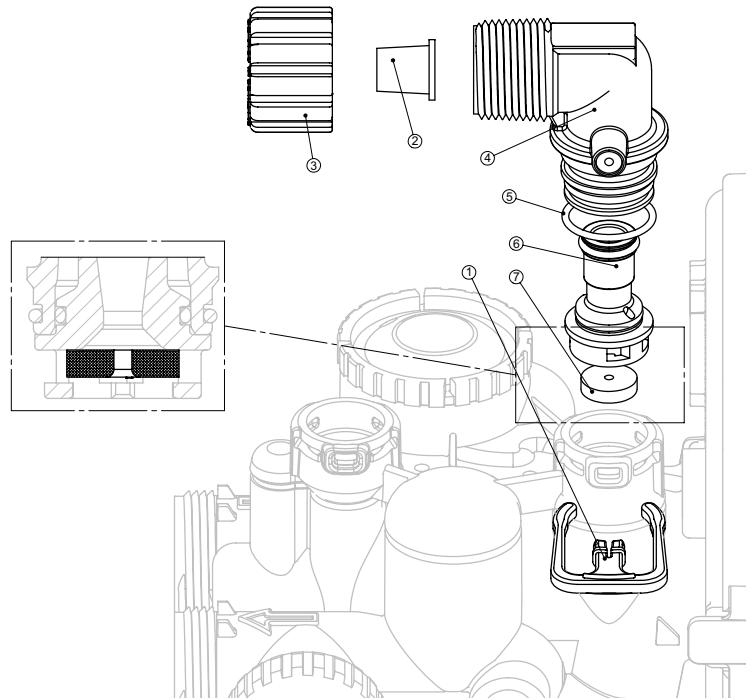

Figure 15

DRAIN LINE - 1"

ITEM NO.	ORDER NO.	DESCRIPTION	QTY.
1	101414	Elbow Locking Clip	1
2	101635	Drain Ftg, 1" Straight Assy-Vent	optional
2	101636	Drain Ftg, 1" Straight Assy-No Vent	1
3*	101244	Drain Ftg Body, 1"	1
4*	101160	Drain Ftg Adapter, 1"	1
5*	102153	O-ring 019	1
6*	102437	Split Ring	1
7*	102141	Nut, 1" QC	1
8*	102165	O-ring 215	1
9	101599	DLFC 9.0 gpm for 1"	One DLFC must be used if 1" fitting is used
	101562	DLFC 10.0 gpm for 1"	
	101564	DLFC 11.0 gpm for 1"	
	101567	DLFC 13.0 gpm for 1"	
	101568	DLFC 15.0 gpm for 1"	
	101571	DLFC 17.0 gpm for 1"	
	101578	DLFC 20.0 gpm for 1"	
	101580	DLFC 25.0 gpm for 1"	

The nuts and caps are designed to be unscrewed or tightened by hand or with the special plastic wrench. If necessary a pliers can be used to unscrew the nut or cap. Do not use a pipe wrench to tighten or loosen nuts or caps. Do not place screwdriver in slots on caps and/or tap with a hammer.

Do not use pipe dope or other sealants on threads. Teflon tape must be used on threads of the 1" NPT connection and on the threads for the drain line connection. Teflon tape is not necessary on the nut connection nor caps because of o-rings seals.

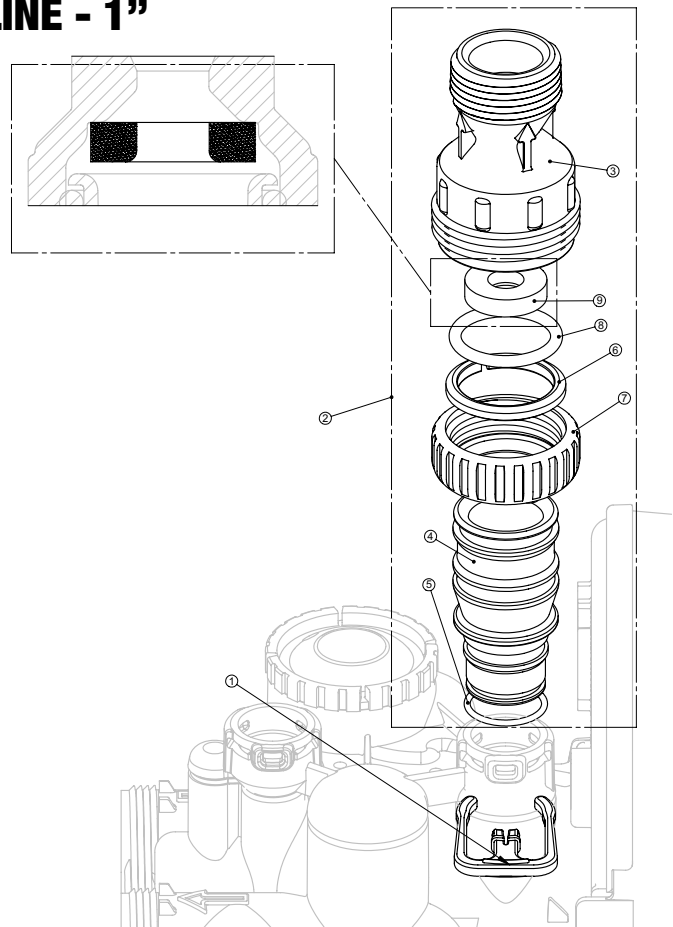

Figure 16

WATER METER AND METER PLUG

ITEM NO.	ORDER NO.	DESCRIPTION	QTY.
1	102141	Nut 1" QC	1
2-4	102051	Meter Assy.	1
3	102687	Turbine Assy.	1
4	102165	O-ring 215	1
5	102321	Meter Plug Assy.**	1

*Order number 102051 includes 102687 and 102165, which are item numbers 3 & 4.

**Only used if metering is not to be done (time clock units)

The nuts and caps are designed to be unscrewed or tightened by hand or with the special plastic wrench. If necessary a pliers can be used to unscrew the nut or cap. Do not use a pipe wrench to tighten or loosen nuts or caps. Do not place screwdriver in slots on caps and/or tap with a hammer.

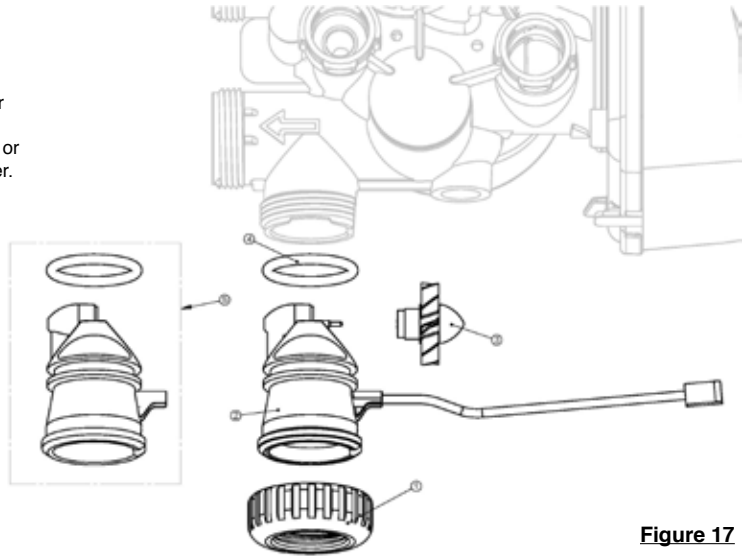

Figure 17

BYPASS VALVE

Bypass Valve

ITEM NO.	ORDER NO.	DESCRIPTION	QTY
1	102141	Nut 1" Quick Connect	2
2	102437	Split Ring	2
3	102165	O'Ring 215	2
4	102450	Bypass 1" Rotor	2
5	110997	Bypass Cap	2
6	110998	Bypass Handle	2
7	109479	Bypass Rotor Seal Retainer	2
8	102159	O-Ring 135	2
9	102161	O-Ring 112	2
10	102160	O-Ring 214	2

(Not Shown) Bypass Vertical Adapter Assembly

ORDER NO.	DESCRIPTION	QTY
102141	Nut 1" Quick Connect	2
102437	Split Ring	2
102165	O'Ring 215	2
106858	Bypass Vertical Adapter	2

The nuts and caps are designed to be unscrewed or tightened by hand or with the special plastic wrench. If necessary a pliers can be used to unscrew the nut or cap. Do not use a pipe wrench to tighten or loosen nuts or caps. Do not place screwdriver in slots on caps and/or tap with a hammer.

Do not use pipe dope or other sealants on threads. Teflon tape must be used on threads of the 1" NPT connection and on the threads for the drain line connection. Teflon tape is not necessary on the nut connection nor caps because of o-ring seals.

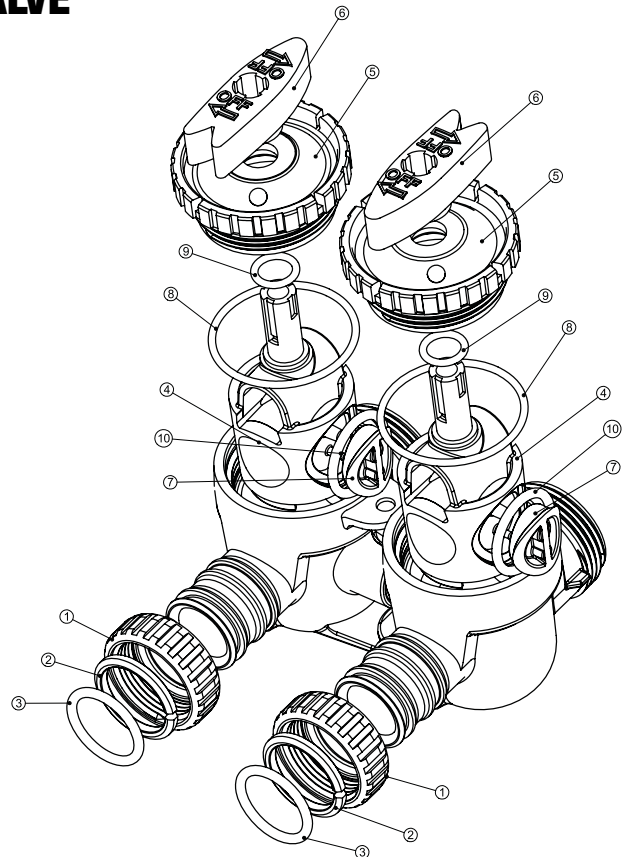
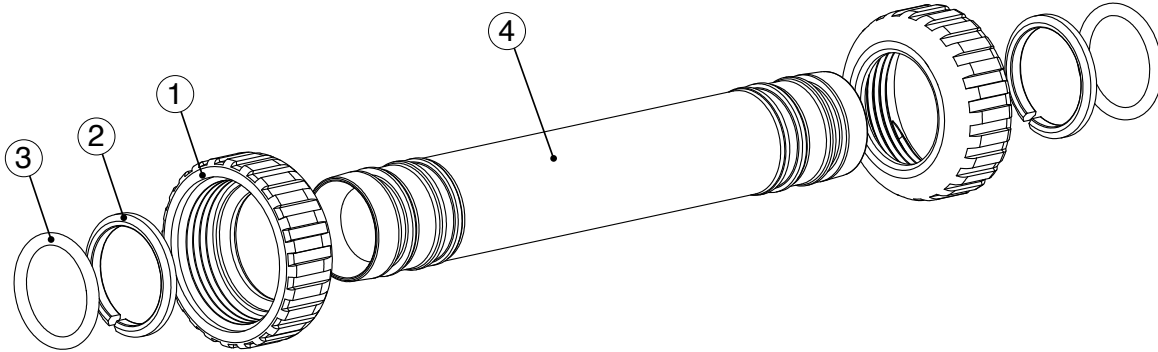

Figure 18

INTERCONNECT FITTING ASSEMBLY – 110194

Used for Tanks up to 10"



Drawing No.	Order No.	Description	Quantity
1	102141	Nut 1" Quick Connect	4
2	102437	Split Ring	4
3	102165	O-Ring 215	4
4	110184	T1 Interconnect Fitting with jackets	2

Fitting Installation Instructions:

- Installation fittings are designed to accommodate minor plumbing misalignments, but are not designed to support the weight of a system or the plumbing.
- Slide nut on first, then the split ring and o-ring.
- Hand tighten the nut only.

IN/OUT HEAD – 101777

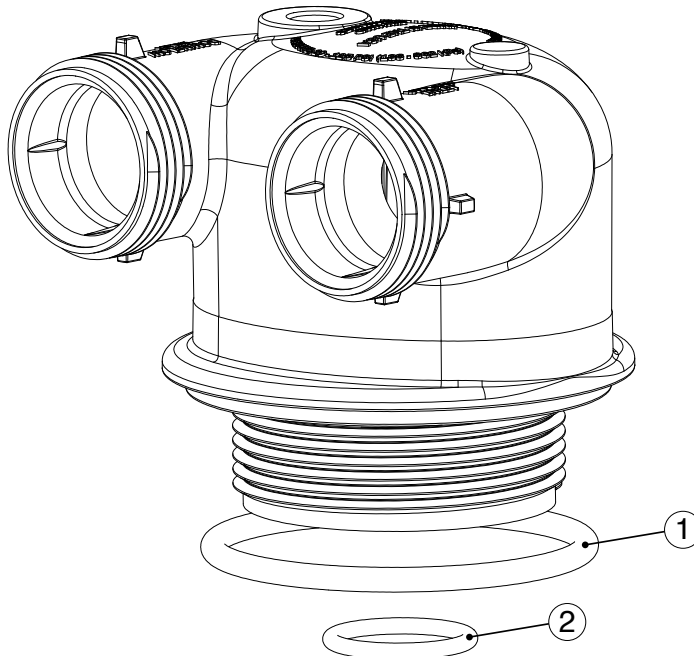

Drawing No.	Order No.	Description	Quantity
1	102192	O-Ring 337	1
2	102165	O-Ring 215 (Distributor Tube)	1

TWIN TRANSFER

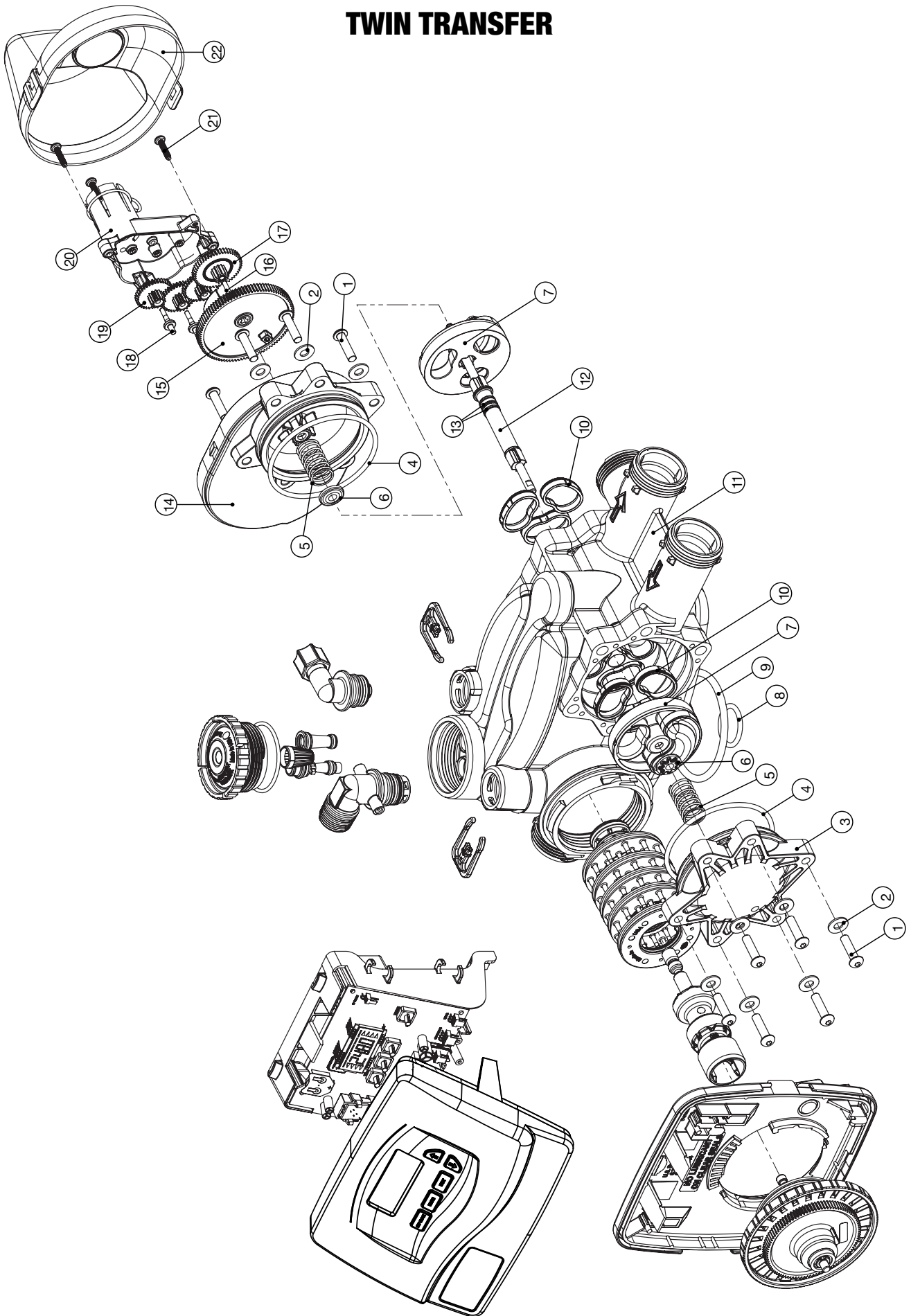

TWIN TRANSFER

Drawing No	Order No	Description	Quantity
1	110196	Screw, BHC 1/4-20 x 1 SS	12
2	109534	Washer Flat SS 1/4	12
3	110197	T1 Transfer Cap Asy	1
4	110198	O-Ring 236	2
5	110199	T1 Transfer Spring	2
6	110200	T1 Transfer Spring Support	2
7	110201	T1 Rotor Disk Asy	2
8	102165	O-Ring 215 (Distributor Tube)	1
9	102192	O-Ring 337	1
10	110202	T1 Transfer Seal	6
11	110203	T1 Body Sft Wtr Regen	1
12	110204	T1 Transfer Drive Shaft Asy	1
13	110205	O-Ring 110	2
14	110206	T1 Transfer Drive Cap Asy	1
15	110207	T1 Transfer Drive Gear Asy	1
16	110208	T1 Transfer Drive Gear Axle	1
17	110209	T1 Transfer Reduction Gear	1
18	106134	WS2H Bypass Reduction Gear Axle	3
19	101746	WS1 Drive Reducing Gear 12x36	3
20	106133	WS1.5&2 Alt/2BY Reduce Gear Cvr Asy	1
21	106139	Screw #8-1 PHPN T-25 SS	3
22	110210	T1 Cover Assembly	1
Not Shown	110211	T1 Transfer Motor Asy	1
Not Shown	102141	W1 Nut 1 QC	1
Not Shown	102048	WS1.5/2L/2H Meter Commercial Asy	1
Not Shown	110194	T1 Interconnect Fitting Asy	1
Not Shown	101777	1191 In/out Head	1

INSTALLATION FITTING ASSEMBLIES

ITEM NO.	ORDER NO.	DESCRIPTION	QTY.
1	102141	Nut 1" Quick Connect	2
2	102437	Split Ring	2
3	102165	O-Ring 215	2
4	106761	Fitting 1" PVC Male NPT Elbow.	2
1-4	101639	Fitting 1" PVC Male NPT Assy. (Set of 2)	1

Figure 19

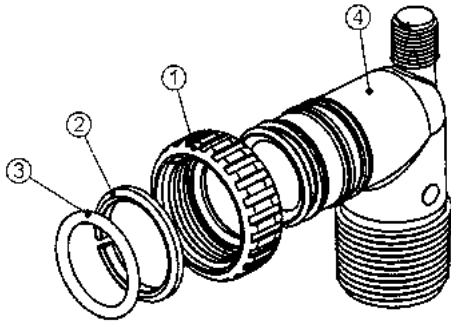

ITEM NO.	ORDER NO.	DESCRIPTION	QTY.
1	102141	Nut 1" Quick Connect	2
2	102437	Split Ring	2
3	102165	O-Ring 215	2
4	106762	Fitting 3/4" & 1" PVC Solv. 90	2
1-4	101640	Fitting 3/4" & 1" PVC Solv 90 (set of 2)	1

Figure 20

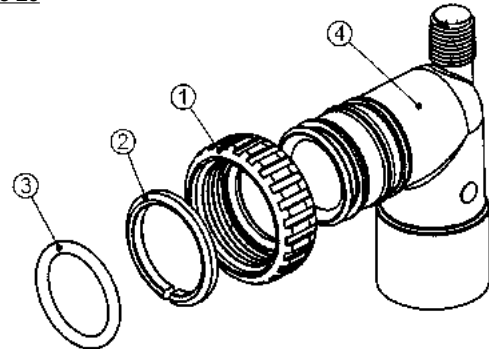

The nuts and caps are designed to be unscrewed or tightened by hand or with the special plastic wrench. If necessary a pliers can be used to unscrew the nut or cap. Do not use a pipe wrench to tighten or loosen nuts or caps. Do not place screwdriver in slots on caps and/or tap with a hammer.

Do not use pipe dope or other sealants on threads. Teflon tape must be used on threads of the 1" NPT connection and on the threads for the drain line connection. Teflon tape is not necessary on the nut connection nor caps because of o-rings seals.

ITEM NO.	ORDER NO.	DESCRIPTION	QTY.
1	102141	Nut 1" Quick Connect	2
2	102437	Split Ring	2
3	102165	O-Ring 215	2
4	106763	Fitting 1" Brass Sweat	2
1-4	108618	Fitting 1" Lead Free Brass Sweat Assy (Set of 2)	1

Figure 21

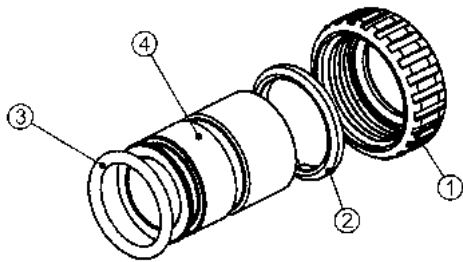

ITEM NO.	ORDER NO.	DESCRIPTION	QTY.
1	102141	Nut 1" Quick Connect	2
2	102437	Split Ring	2
3	102165	O-Ring 215	2
4	106764	Fitting 1" Brass Sweat	2
1-4	108617	Fitting 1" Lead Free Brass Sweat Assy (Set of 2)	1

Figure 22

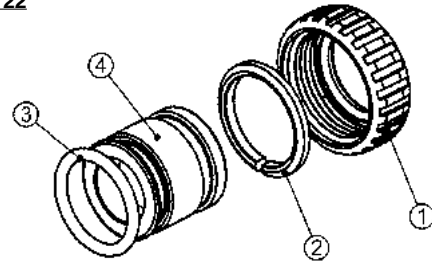

ITEM NO.	ORDER NO.	DESCRIPTION	QTY.
1	102141	Nut 1" Quick Connect	2
2	102437	Split Ring	2
3	102165	O-Ring 215	2
4	106765	Fitting 1" Plastic Male NPT	2
1-4	101643	Fitting 1" Male NPT Assy. (Set of 2)	1

Figure 23

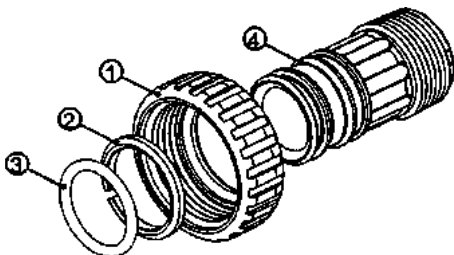

ITEM NO.	ORDER NO.	DESCRIPTION	QTY.
1	102141	Nut 1" Quick Connect	2
2	102437	Split Ring	2
3	102165	O-Ring 215	2
4	106766	Fitting 1-1/4" Plastic Male NPT	2
1-4	101644	Fitting 1-1/4" Male NPT (Set of 2)	1

Figure 24

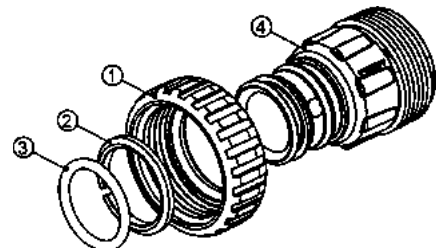

ITEM NO.	ORDER NO.	DESCRIPTION	QTY.
1	102141	Nut 1" Quick Connect	2
2	102437	Split Ring	2
3	102165	O-Ring 215	2
4	106787	Fitting 1-1/4" & 1-1/2" Brass Sweat	2
1-4	108619	Fitting 1-1/4" & 1-1/2" Brass Swt Assy.(Set of 2)	1

Figure 25

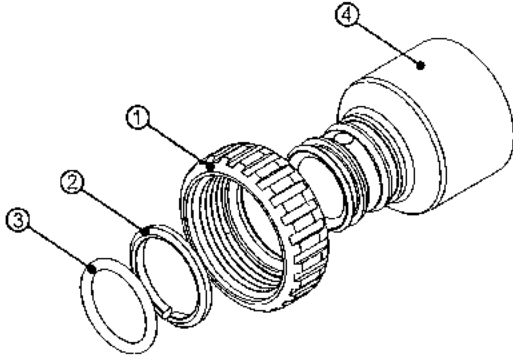

ITEM NO.	ORDER NO.	DESCRIPTION	QTY.
1	102141	Nut 1" Quick Connect	2
2	102437	Split Ring	2
3	102165	O-Ring 215	2
4	106769	Fitting 3/4" Brass Sharkbite	2
1-4	110135	Fitting 3/4" Brass Sharkbite Assy.(Set of 2)	1

Figure 27

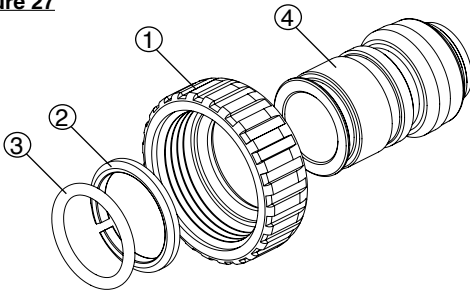

ITEM NO.	ORDER NO.	DESCRIPTION	QTY.
1	102141	Nut 1" Quick Connect	2
2	102437	Split Ring	2
3	102165	O-Ring 215	2
4	108478	Fitting 3/4" John Guest	2
1-4	108478	Fitting 3/4" JG QC Assy (Set of 2)	1

Figure 29

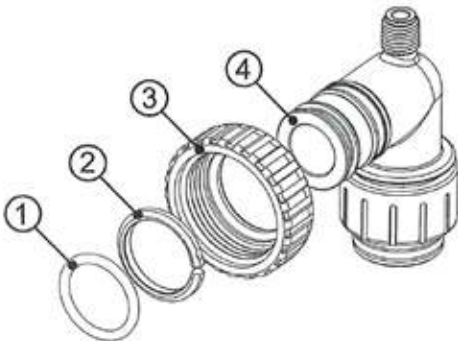

ITEM NO.	ORDER NO.	DESCRIPTION	QTY.
1	102141	Nut 1" Quick Connect	2
2	102437	Split Ring	2
3	102165	O-Ring 215	2
4	106786	Fitting 1-1/4" & 1-1/2" PVC Solvent	2
1-4	101646	Fitting 1-1/4" & 1-1/2" PVC Solvent Assy.(Set of 2)	1

Figure 26

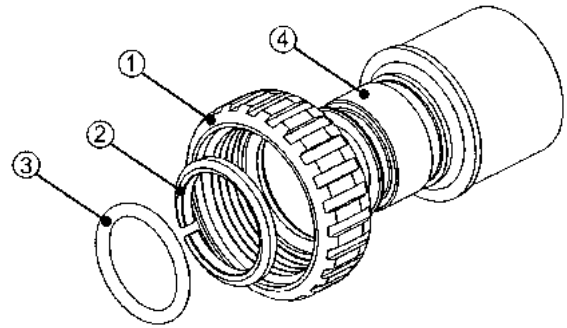

ITEM NO.	ORDER NO.	DESCRIPTION	QTY.
1	102141	Nut 1" Quick Connect	2
2	102437	Split Ring	2
3	102165	O-Ring 215	2
4	106770	Fitting 1" Brass Sharkbite	2
1-4	110136	Fitting 1" Brass Sharkbite Assy. (Set of 2)	1

Figure 28

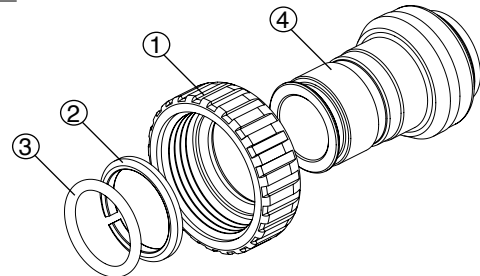

TWIN ALTERNATING DOWNFLOW SYSTEM SPECIFICATIONS

MODEL	PM7.0-024TA	PM7.0-032TA	PM7.0-032-10 TA	PM7.0-048TA	PM7.0-064TA	PM7.0-096TA	PM7.0-128TA	PM7.0-160TA	PM7.0-192TA	
FACTORY PRESET MINUTES										
PRE-RINSE: **	Minutes	off	off	off	off	off	off	off	off	off
	GALLONS	off	off	off	off	off	off	off	off	off
FILL:	MINUTES	3.0	4.0	4.0	6.0	8.0	12.0	16.0	20.0	24.0
	GALLONS	1.5	2.0	2.0	3.0	4.0	6.0	8.0	10.0	12.0
BACKWASH:	MINUTES	8.0	8.0	8.0	8.0	8.0	8.0	8.0	8.0	8.0
	GALLONS	10.4	13.6	17.6	17.6	33.6	33.6	42.4	60.0	60.0
BRINE:	MINUTES	60.0	60.0	60.0	60.0	68.0	68.0	68.0	68.0	68.0
	GALLONS	14.4	16.2	16.2	19.2	38.1	42.5	57.8	78.2	112.2
RINSE:	MINUTES	4.0	4.0	4.0	4.0	4.0	4.0	4.0	4.0	4.0
	GALLONS	5.2	6.8	8.8	8.8	16.8	16.8	21.2	30.0	30.0
TOTAL REGENERATION IN GALLONS @35 PSI, INCLUDES BRINE MAKE UP.										
		32.1	39.2	45.2	49.8	95.2	101.3	139.6	185.0	217.6
REFILL-POUNDS OF SALT										
HIGH EFFICIENCY SALTING		2.5	3.3	3.3	4.95	6.6	9.9	13.2	16.5	19.8
LOW SALTING		4.5	6	6	9	12	18	24.0	30.0	36.0
MEDIUM SALTING		7.5	10	10	15	20	30	40.0	50.0	60.0
HIGH SALTING		11.5	15	15	22.5	30	45	60.0	75.0	90.0
CAPACITY-GRAINS										
HIGH EFFICIENCY SALTING		10,492	13,972	13,972	20,958	27,944	41,916	55,888	69,861	83,833
LOW SALTING		17,200	22,930	22,930	34,400	45,870	68,810	91,750	114,690	137,620
MEDIUM SALTING		21,040	28,060	28,060	42,090	56,120	84,180	112,240	140,300	168,360
HIGH SALTING		24,230	32,310	32,310	48,460	64,620	96,930	129,240	161,550	193,860
SERVICE FLOW RATE**										
FLOW RATE AT 10 PSI		9.8	10.1	11.3	10.5	14.2	14.4	15.1	17.3	17.2
FLOW RATE AT 15 PSI		13.1	13.0	14.5	14.1	18.2	19.2	20.1	22.7	21.7
OTHER DATA										
RESIN, CUBIC FEET		0.75	1	1	1.5	2	3	4	5	6
GRAVEL UNDERBED CF *		NA	NA	NA	NA	NA	NA	0.4	0.5	0.5
MINERAL TANK DIMENSIONS		8x44	9x48	10x44	10x54	13x54	14x65	16x65	18x65	18x65
BRINE TANK DIMENSIONS		18x40	18x40	18x40	18x40	18x40	24x41	24x41	24x50	24x50
DRAIN LINE FLOW CONTROL RATE GPM		1.3	1.7	2.2	2.2	4.2	4.2	5.3	7.5	7.5
BRINE LINE FLOW CONTROL RATE GPM		0.5	0.5	0.5	0.5	0.5	0.5	0.5	0.5	0.5
INJECTOR SIZE-COLOR		C-Violet	D-Red	D-Red	E-White	G-Yellow	H-Green	I-Orange	J-L. Blue	K-L. Green
INJECTOR DRAW RATE AT 35 PSI		0.135	0.21	0.21	0.25	0.41	0.425	0.52	0.61	0.63
INJECTOR SLOW RINSE RATE AT 35 PSI		0.24	0.27	0.27	0.32	0.56	0.625	0.85	1.15	1.65

***Vortech tanks do not require gravel.**

Factory Settings are in bold. Factory settings are programmed for clean, iron-free water such as city water supplies, specifically for efficient salt use. On water supplies with turbidity and/or iron concentrations >0.5 ppm, programming second backwash cycle after brine cycle may be required to maintain resin for optimal performance. Higher salting levels or resin cleaners may be needed for high iron levels.

System conforms to ANSI/NSF 44 for specific performance claims as verified and substantiated by test data. Efficiency is measured by a laboratory test as described in NSF/ANSI 44, testing represents maximum efficiency system can achieve. Operational efficiency is achieved after system is installed and may be less than tested efficiency due to application parameters such as water hardness, TDS and other contaminants that reduce the softeners capacity.

If application demands 1 gpg or less in service flow at peak flows, may need to add safety factor when programming capacity.

Residential Water Softener & Filter Limited Warranty

**INCLUDES – ProMate®, ProMate-1®, ProMate-5®, ProMate-6®, ProMate-6 DMT®, ProMate-6.5 DMT®,
ProMate-7.0®, ProMate®-EcoMax, ProMate®-EcoMax Duo and E6
EXCLUDES – Iron Curtain®, Iron Curtain® Jr. and Storm Filter Systems**

Hellenbrand warrants to the original consumer purchaser that the System and the parts listed below will be free from defects in material and/or workmanship from the date of the original installation for the following time periods:

For a Period of FIVE YEARS: The filter control valve electrical parts including the motor and board, control valve body, and internal parts.

For a Period of TEN YEARS: Mineral tanks, 6" Diameter - 13" Diameter.

For a Period of FIVE YEARS: Mineral tanks, 14" Diameter - Up.

For a Period of FIVE YEARS: The salt storage/cabinet tank.

For a Period of ONE YEAR: The entire water conditioner system ("System").

Any parts used for replacement are warranted for the remainder of the original warranty period for the applicable part.

THIS WARRANTY IS EFFECTIVE TO THE ORIGINAL CONSUMER PURCHASER ONLY, AND ONLY FOR AS LONG AS THE SYSTEM REMAINS AT THE ORIGINAL INSTALLATION SITE. COVERAGE TERMINATES IF YOU SELL OR OTHERWISE TRANSFER THE SYSTEM OR IF THE SYSTEM IS MOVED FROM THE ORIGINAL INSTALLATION SITE.

No sales representative, distributor, agent, dealer, reseller, authorized seller or any other person or entity is authorized to make any other warranty, or modify or expand the warranty provided herein on behalf of Hellenbrand. Upon expiration of the applicable warranty period, Hellenbrand shall have no further liability related to the System/parts to which the warranty period applies, except with respect to valid warranty claims asserted during the appropriate warranty period.

If the System or any part described above becomes defective within the specified warranty period, you should notify your local authorized seller of Hellenbrand products, and arrange a time during normal business hours for the inspection of the System at the original installation site. You may also contact Hellenbrand and we will provide you with the contact information for your local authorized seller of Hellenbrand products. Hellenbrand, at its option, will repair or replace the System or any part found defective within the terms of this warranty. You are responsible for freight from our factory and any service fees charged by the local authorized seller of Hellenbrand products for installation, repair, removal, replacement, service, etc., of any System or parts. This warranty does not include any labor charges. This paragraph sets forth the exclusive remedy for any valid warranty claims against Hellenbrand.

THIS WARRANTY DOES NOT COVER defects caused by sand, sediment or bacteria fouling, accident, fire, flood, Act of God, misuse, misapplication, neglect, alteration, installation or operation contrary to Hellenbrand's printed instructions, or installation, repair or service by anyone other than Hellenbrand or an authorized seller of Hellenbrand products.

IN ADDITION, THIS WARRANTY DOES NOT COVER UNPROTECTED OUTDOOR INSTALLATIONS. This System, including all of the electrical components, must be protected against windblown dust, falling and windblown rain, freezing temperatures and the formation of ice, with an appropriate enclosure consisting of a floor, roof, walls, ventilation and heat.

As a manufacturer, we do not know the characteristics of your water supply or the purpose for which you are purchasing this system. You should be aware that the quality of water supplies may vary seasonally or over a period of time, and that your water usage rate may vary as well. Water characteristics may change considerably if this System is moved to a new location. For these reasons, Hellenbrand assumes no liability for the determination of the proper equipment necessary to meet your needs; and Hellenbrand does not authorize others to assume such obligations for Hellenbrand.

TO THE EXTENT PERMITTED BY APPLICABLE LAW, REMEDIES FOR DEFECTS OR FAILURES ARE LIMITED TO THE REMEDIES PROVIDED IN THIS WARRANTY. THERE ARE NO EXPRESS WARRANTIES OTHER THAN THOSE SET FORTH HEREIN. ANY IMPLIED WARRANTIES, INCLUDING WITHOUT LIMITATION WARRANTIES OF MERCHANTABILITY, FITNESS FOR PARTICULAR PURPOSE, NON-INFRINGEMENT, OR ANY WARRANTIES ARISING FROM COURSE OF PERFORMANCE, COURSE OF DEALING, OR FROM USAGES OF TRADE, ARE LIMITED IN DURATION TO THE APPLICABLE WARRANTY PERIOD SET FORTH ABOVE.

UNDER NO CIRCUMSTANCES SHALL HELLENBRAND BE LIABLE TO THE ORIGINAL CONSUMER PURCHASER OR TO ANY OTHER PERSON FOR ANY INCIDENTAL, INDIRECT, SPECIAL OR CONSEQUENTIAL DAMAGES OR FOR ANY OTHER LOSS, DAMAGE, OR EXPENSE OF ANY KIND, INCLUDING LOSS OF PROFITS, WHETHER ARISING OUT OF BREACH OF WARRANTY, BREACH OF CONTRACT, IN TORT OR OTHERWISE, AND REGARDLESS OF WHETHER HELLENBRAND WAS AWARE OF THE POSSIBILITY OF SUCH LOSS. THESE LIMITATIONS WILL APPLY REGARDLESS OF ANY FAILURE OF ESSENTIAL PURPOSE OF ANY LIMITED REMEDY.

Some states do not allow limitations on how long an implied warranty lasts, so the above limitations may not apply to you. Similarly, some states do not allow the exclusion or limitation of incidental or consequential damages, so the above limitation or exclusion may not apply to you. This warranty gives you specific legal rights, and you may also have other rights which vary from state to state. Hellenbrand products are not for sale or distribution into the State of California effective 8/31/18.